

# The Harman Kardon Model HD7525 COMPACT DISC PLAYER

Manual A

## Technical Manual

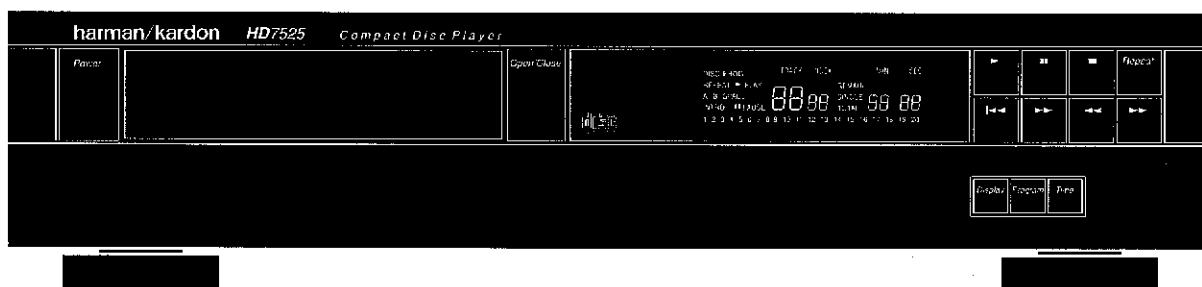

**The following marks found in the parts list of this manual identify the models as follows:**

- Ⓚ : North America area model Black version
- Ⓜ : International model Black version
- ⓐ : General Model
- ⓑ : General Model Black Version

**harman/kardon**

240 Crossways Park West, Woodbury, N. Y. 11797  
1112-HD7525-A P9307 1200 Printed in USA

**CLASS 1 LASER PRODUCT**

Product complies with DHHS rules CFR subchapter J part 1040.10 at date of manufacture.

**DANGER** - invisible laser radiation when open and interlock failed or defeated. Avoid direct exposure to the beam.

**CAUTION** - use of all controls, adjustments or performance of procedures other than those specified herein may result in hazardous radiation exposure.

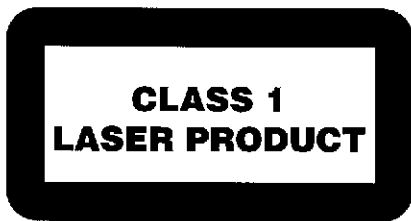

**Be careful of the Laser Pickup.**

Although you cannot see it from the outside, a laser pickup is located under the disc tray and a precision lens is built in it.

Since the laser pickup, including the lense element, is especially sensitive to dust, keep the disc tray closed when not in use. Also do not put your hand inside the unit.

**ADVARSEL:**

Usynlig laserstråling ved åbning når sikkerhedsafbrydere er ude af funktion. Undgå udsættelse for stråling.

**VAROITUS!**

Laite sisältää laserdiodin, joka lähettää näkymätöntä silmille vaarallista lasersäteilyä.

**CONTENTS**

SPECIFICATIONS ..... 1  
 SAFETY PRECAUTIONS..... 2  
 AC LEAKAGE TEST ..... 2  
 ELECTROSTATICALLY SENSITIVE DEVICES ..... 3  
 CONTROLS AND FUNCTIONS ..... 4  
 REMOTE CONTROL ..... 5  
 DISASSEMBLY PROCEDURES ..... 6  
 POWER CORD REPLACEMENT ..... 7  
 ADJUSTMENT PROCEDURE..... 8  
 TROUBLESHOOTING ..... 10  
 IC FUNCTIONS ..... 14

CIRCUIT DESCRIPTION ..... 19  
 GENERAL UNIT (EXPLODED VIEW) ..... 23  
 CD MECHANISM (EXPLODED VIEW) ..... 25  
 GENERAL PARTS LIST..... 26  
 CD MECHANISM PARTS LIST ..... 27  
 ELECTRICAL PARTS LIST ..... 28  
 IC DIAGRAMS..... 32  
 P. C. BOARDS ..... 36  
 WIRING DIAGRAM..... 38  
 SCHEMATIC DIAGRAM..... 39

**SPECIFICATIONS**

	<b>Nominal</b>	<b>Limit</b>
System	: Compact Disc Digital Audio	
D/A Converter	: Dual 18 Bit Linear D/A Converters, 4Fs Digital Filter, RLS (Real-time Linear Smoothing)	
Signal Detection	: 3-Beam Semiconductor Optical Laser Pickup	
Error Correction	: CIRC System	
Low Level Linearity	: +/-1.0dB @ -90dB	
Frequency Response	: 0dB	0.5dB
(20Hz to 20kHz)		±
Total Harmonic Distortion (THD)	: 0.004%	<0.008%
Dynamic Range	: 96dB	≥90dB
Signal to Noise Ratio	: 104dB	≥100dB
Channel Separation	: 98dB	≥90dB
Line Output Level/Impedance	: 2.0V	±0.0V 0.5V @ 10k
Digital Output Level/Impedance	: 0.5Vp-p	0.5Vp <sup>±</sup> p 0.1Vp-p @75
Power Supply		± Ω
U.S.A. and Canada models	: AC120v, 60Hz	
International, Australia and Asia/Oceania models	: AC230/240V, 50/60Hz	
Power Consumption	: 20 Watts	
Dimensions	: 173/8" x 4" x 13"	
	443mm x 103mm x 326mm	
Weight	: 11.5lbs/5.2kg	

Specifications and components subject to change without notice. Overall performance will be maintained or improved.

## SAFETY PRECAUTIONS

Before returning an instrument to the customer, always make a safety check of the entire instrument, including, but not limited to, the following items:

- a. Be sure that no built-in protective devices are defective and/or have been defeated during servicing.
  - (1) Protective shields are provided to protect both the technician and the customer. Correctly replace all missing protective shields, including any removed for servicing convenience.
  - (2) When reinstalling the chassis and/or other assembly in the cabinet, be sure to put back in place all protective devices, including, but not limited to, nonmetallic control knobs, insulating fishpapers, adjustment and compartment covers/shields, and isolation resistor/capacitor networks.

**Do not operate this instrument or permit it to be operated without all protective devices correctly installed and functioning.**

- b. Be sure that there are no cabinet openings through which an adult or child might be able to insert their fingers and contact a hazardous voltage. Such openings include, but are not limited to, excessively wide cabinet ventilation slots, and an improperly fitted and/or incorrectly secured cabinet back cover.

c. **Leakage Current Hot Check** - With the instrument completely reassembled, plug the AC line cord directly into a 120V AC outlet (do not use an isolation transformer during this test). Use a leakage current tester or a metering system that complies with American National Standards Institute (ANSI) C101.1 "Leakage Current for Appliances" and Underwriters Laboratories (UL) 1270, (34.6). With the instrument AC switch first in the ON position and then in the OFF position, measure from a known earth ground (metal waterpipe, conduit, etc.) to all exposed metal parts of the instrument (antennas, handle bracket, metal cabinet, screwheads, metallic overlays, control shafts, etc.), especially any exposed metal parts that offer an electrical return path to the chassis. Any current measured must not exceed 0.5 milliamp. Reverse the instrument power cord plug in the outlet and repeat test. **ANY MEASUREMENTS NOT WITHIN THE LIMITS SPECIFIED HEREIN INDICATE A POTENTIAL**

### AC LEAKAGE TEST

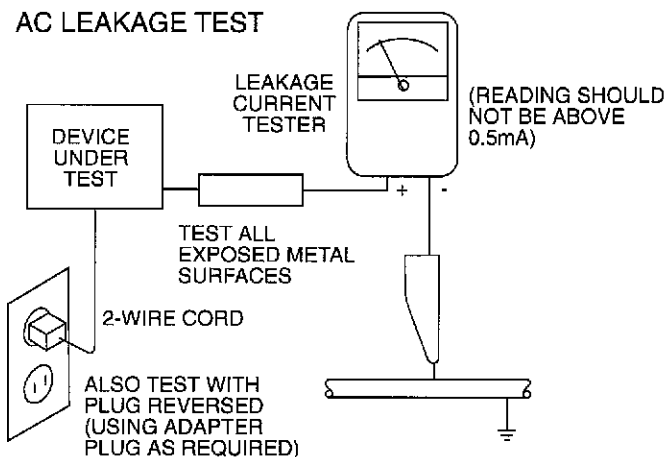

## SHOCK HAZARD THAT MUST BE ELIMINATED BEFORE RETURNING THE INSTRUMENT TO THE CUSTOMER.

### d. Insulation Resistance Test

- (1) Unplug the power supply cord and connect a jumper wire between the two prongs of the plug.
- (2) Turn on the power switch of the instrument.
- (3) Measure the resistance with an ohmmeter between the jumpered AC plug and each **exposed metallic** cabinet part on the instrument, such as screwheads, antenna, control shafts, handle brackets, etc. The reading should be as shown below. If it is not within the limits specified, there is the possibility of a shock hazard, and the instrument must be repaired and rechecked before it is returned to the customer.

### e. Insulation Resistance Test Cold Check

- (1) Unplug the power supply cord and connect a jumper wire between the two prongs of the plug.
- (2) Turn on the power switch of the instrument.
- (3) Measure the resistance with an ohmmeter between the jumpered AC plug and each **exposed metallic cabinet** part on the instrument, such as screw heads, antenna, control shafts, handle brackets, etc. When the exposed metallic part has a return path to the chassis, the reading should be between 1 and 5.2 Megohm. When there is no return path to the chassis, the reading must be "infinite".

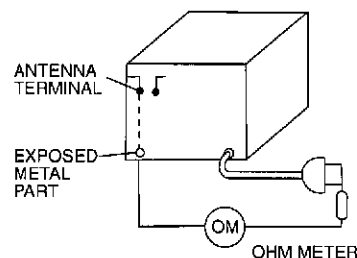

If it is not within the limits specified, there is the possibility of a shock hazard, and the instrument must be repaired and rechecked before it is returned to the customer.

### PRODUCT SAFETY NOTICE

Some electrical and mechanical parts have special safety-related characteristics which are often not evident from visual inspection, nor can the protection they give necessarily be obtained by replacing them with components rated for higher voltage, wattage, etc. Parts that have special safety characteristics are identified by shading, by (  $\Delta$  ) on schematics and parts list. Use of a substitute replacement that does not have the same safety characteristics and parts listed. Use of a substitute replacement that does not have the same safety characteristics as the recommended replacement part might create shock, fire, and/or other hazards. Products Safety is under review continuously and new instructions are issued whenever appropriate.

### SERVICING PRECAUTIONS

**CAUTION:** Before servicing instruments covered by this manual and its supplements, read and follow the SAFETY PRECAUTIONS on this page.

**NOTE:** If unforeseen circumstances create conflict between the following servicing precautions and any of the safety precautions, **always follow the safety precautions.**

Remember: Safety First.

### General Servicing Precautions

- a. Always unplug the instrument's AC power cord from the AC power source before:
  - (1) Removing or reinstalling any component, circuit board, module, or any other instrument assembly.
  - (2) Disconnecting or reconnecting any instrument electrical plug or other electrical connection.
  - (3) Connecting a test substitute in parallel with an electrolytic capacitor in the instrument.
 

**Caution:** A wrong part substitution or incorrect polarity installation of electrolytic capacitors may result in an explosion hazard.
- b. Do **not** defeat any plug/socket B+ voltage interlocks with which instruments covered by this manual might be equipped.
- c. Do **not** apply AC power to this instrument and/or any of its electrical assemblies unless all solid-state device heat sinks are correctly installed.
- d. Always connect a test instrument's ground lead to the instrument chassis ground before connecting the test instrument positive lead. Always remove the test instrument ground lead last.

**NOTE:** Refer to Safety Precautions on Page 2.

- (1) The service precautions are indicated or printed on the cabinet, chassis or components. When servicing, follow the printed or indicated service precautions and service materials.
- (2) The Components used in the unit has a specified flammability and dielectric strength. When replacing any components, use components which has the same ratings. Components marked (  $\Delta$  ) in the circuit diagram are important for safety or for the characteristics of the unit. Always replace with the appointed components.
- (3) An insulation tube or tape is sometimes used and some components are raised above the printed wiring board for safety. The internal wiring is sometimes clamped to prevent contact with heating components. Install them as they were.
- (4) After servicing, always check that the removed screws, components and wiring have been installed correctly and that the portion around the service part have not been damaged and so on. Further check the insulation between the blades of attachment plug and accessible conductive parts.

### Insulation Checking Procedure

Disconnect the attachment plug from the AC outlet and turn the power on. Connect the insulation resistance meter (500V) to the blades of the attachment plug. The insulation resistance between each blade of the attachment plug and accessible conductive parts (Note 1) should be more than 1M-ohm.

**NOTE:** Accessible Conductive Parts including Metal panels, Output jacks, etc.

## ELECTROSTATICALLY SENSITIVE (ES) DEVICES

Some semiconductor (solid state) devices can be damaged easily by static electricity. such components commonly are called Electrostatically Sensitive (ES) Devices. Examples of typical ES devices are integrated circuits and some field effect transistors and semiconductor "chip" components. The following techniques should be used to help reduce the incidence of component damage caused by static electricity.

1. Immediately before handling any semiconductor component or semiconductor-equipped assembly, drain off any electrostatic charge on your body by touching a known earth ground. Alternatively, obtain and wear a commercially available discharging wrist strap device, which should be removed for potential shock reasons prior to applying power to the unit under test.
2. After removing an electrical assembly equipped with ES devices, place the assembly on a conductive surface such as aluminum foil, to prevent electrostatic charge buildup or exposure of the assembly.
3. Use only a grounded-tip soldering iron to solder or unsolder ES devices.
4. Use only an anti-static solder removal device. Some solder removal devices not classified as "anti-static" can generate electrical charges sufficient to damage ES devices.
5. Do not use freon-propelled chemicals. These can generate electrical charge sufficient to damage ES devices.
6. Do not remove a replacement ES device from its protective package until immediately before you are ready to install it. (Most replacement ES devices are packaged with leads electrically shorted together by conductive foam, aluminum foil or comparable conductive material.)
7. Immediately before removing the protective material from the leads of a replacement ES device, touch the protective material to the chassis or circuit assembly into which the device will be installed.
 

**CAUTION:** Be sure no power is applied to the chassis or circuit, and observe all other safety precautions.
8. Minimize bodily motions when handling unpackaged replacement ES devices. (Otherwise harmless motion such as the brushing together of your clothes fabric or the lifting of your foot from a carpeted floor can generate static electricity sufficient to damage an ES device.)

## CONTROLS AND FUNCTIONS

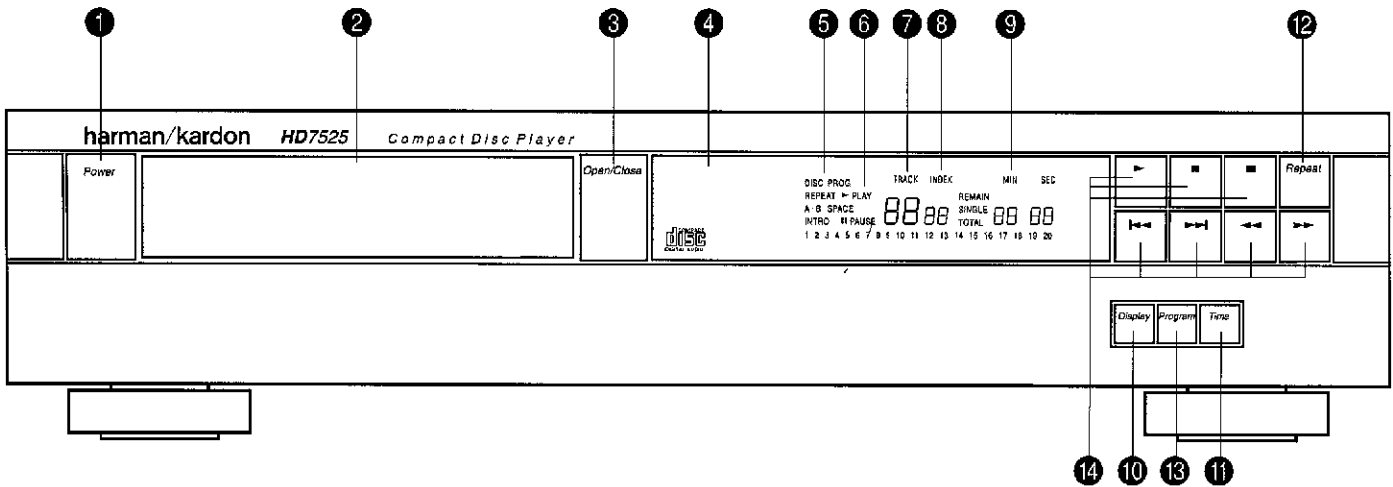

### 1 POWER switch

The POWER switch turns the unit on and off.

### 2 Compact disc drawer

Load a disc (full-size or 3-inch/8cm) into your compact disc player by placing it in this drawer with the label side up. Open and close the drawer using the OPEN/CLOSE button (3).

### 3 OPEN/CLOSE button

Press this button to open or close the compact disc drawer. The drawer will also close if you press the play button or push the drawer gently toward the chassis of the player; however, we recommend that you do not push the drawer.

### 4 REMOTE sensor

This area receives the signal from the remote control unit. Make sure this area of the front panel is kept free from dirt or other obstructions that might prevent proper reception of the infrared signal from the remote control.

### 5 FUNCTION indicator

DISC - This indicator lights when the disc drawer is open, and when a disc is loaded. It does not light when there is no disc.

REPEAT - When this indicator is lit, the unit is in REPEAT mode and will continuously repeat either the entire disc or the programmed sequence.

A-B - When this indicator is lit steadily, the unit is set to repeat a specified section of the disc (from A to B). When REPEAT indicator is lit, you have already programmed the starting point (point A) of a section, and the unit is waiting for you to program the ending point of the section (point B).

INTRO - When this indicator is lit, the unit is in INTRO SCAN mode and will play only the first 15 seconds of each selection on the disc or in the selected program.

PROG - When this indicator is lit, the unit is in PROGRAM mode, in which you can program a sequence of tracks in the order you'd like to hear them, then play back you programmed sequence.

SPACE - When this indicator is lit, the unit is in SPACE mode and will insert 4 seconds of space between tracks.

### 6 PLAYBACK mode

PLAY - This indicator is lit when the unit is playing a track.

PAUSE - This indicator is lit when the unit is in PAUSE mode (i.e., you have pressed PAUSE to temporarily stop playback).

### 7 TRACK indicator

When a disc is loaded but not playing, the TRACK indicator displays the total number of tracks on that disc. During playback, the indicator displays the number of the track currently being played. During programming, it displays the number of the track most recently selected.

### 8 INDEX indicator

Some discs that contain very long tracks may have those tracks subdivided into shorter section. For example, a long classical piece may be divided into movement, each of which may have an index number. The INDEX indicator displays the number of the subdivision of a track currently being played. If the track has no subdivisions, the INDEX indicator will display a 1 during playback. During programming, the INDEX light goes out and the indicator displays the total number of tracks selected in the programmed sequence.

### 9 TIME indicator

When a disc is loaded but not playing, the TIME indicator displays the total amount of playback time on that disc. During playback, depending on the state of the TIME button (11), the indicator displays one of the following:

- The time that has elapsed since the beginning of the current track.
- The time that remains on the currently selected track. The words REMAIN SINGLE will be displayed if the indicator is in this mode.
- The time that remains on either the entire disc or on the programmed selections. The words REMAIN TOTAL will be displayed if the indicator is in this mode. Note that if you have programmed more than 99 minutes in your selection, only dashes will appear in this mode.

### 10 DISPLAY button

This button turns the display on and off. When you turn the display off in PLAY mode, the entire display goes off. In PAUSE mode, most of the display goes off, but the track number is still displayed. In STOP mode, most of the display goes off, but the total number of tracks on the disc is still displayed. In some systems, turning the fluorescent display off may provide the purest possible sound quality during playback.

**11 TIME button**

During playback or programming, the button cycles through the three TIME display modes:

- The time that has elapsed since the beginning of the current track.
- The time that remains on the currently selected track.
- The time that remains on either the entire disc or the programmed sequence.

**12 REPEAT button**

This button puts your compact disc player in and out of REPEAT mode. In REPEAT mode, the unit will continually play back either the entire disc or the programmed sequence of tracks. Press the button once to turn on REPEAT mode; press again to turn off REPEAT mode. When the unit is in REPEAT mode, the FUNCTION indicator (5) will display the word REPEAT.

**13 PROGRAM button**

This button puts your compact disc player in and out of PROGRAM mode. Press the button once to turn on PROGRAM mode; press again to turn it off. In PROGRAM mode, you can program a set of tracks to play in any sequence. (For instructions on programming a sequence of tracks, see the Operations section of this manual.) When the unit is in PROGRAM MODE, the function indicator (5) will display the word PROG in red.

**14 Playback controls**

- PLAY -- The PLAY button starts playback of a track.
- PAUSE -- Pressing the PAUSE button temporarily stops playback. Pressing the PAUSE button again, or pressing PLAY, resumes playback at the precise point where playback left off.
- STOP -- The STOP button stops playback. When you press PLAY, playback will start either at the beginning of the disc or programmed sequence, or at any track you select.
- SKIP BACK -- Pressing this button once skips back to the beginning of the present track. If you are in PLAY mode, playback will resume. Holding the button down skips backward to the beginning of each preceding track until the first track on the disc is reached.
- SKIP FORWARD -- Pressing this button once skips forward to the beginning of the next track. If you are in PLAY mode, playback will resume. Holding the button down skips forward to the beginning of each subsequent track until the last track on the disc is reached.
- SEARCH BACK -- Holding down this button during playback reverses rapidly through the disc. This function is similar to the "rewind" function on a tape deck.
- SEARCH FORWARD -- Holding down this button during playback speeds rapidly forward through the disc. This function is similar to the "fast forward" function on a tape deck.

**REMOTE CONTROL**

The remote control for the HD7525 provides the same functions found on the front panel of the compact disc player itself. In addition, the remote control provides some functions that are not found on the front panel.

The functions found on the remote control that are not found on the front panel are INTRO, A-B, INDEX, SPACE, AND THE 1-10 and +10 keys. These five functions are described below (for other functions, see the descriptions above).

**15 CLEAR button**

The CLEAR button removes tracks from your programmed sequence one by one starting with the last track entered. Each time you clear a track from the programmed sequence, that track's time is deleted from the total time displayed. This button is used only in PROGRAM mode.

**16 CHECK button**

When a disc is loaded but not playing (STOP mode), you can press the CHECK button to see the playback time of each track on the disc. Each time you press the CHECK button, the next track is displayed along with its playback time. When you have stepped sequentially through all the tracks on the disc, another press of the CHECK button displays the total playback time of the entire disc. In PROGRAM mode, the CHECK button displays the cumulative time of the tracks in the programmed sequence. That is, the first press displays the time of the first programmed track, the second press displays the cumulative playback time of the first and second tracks, and so on.

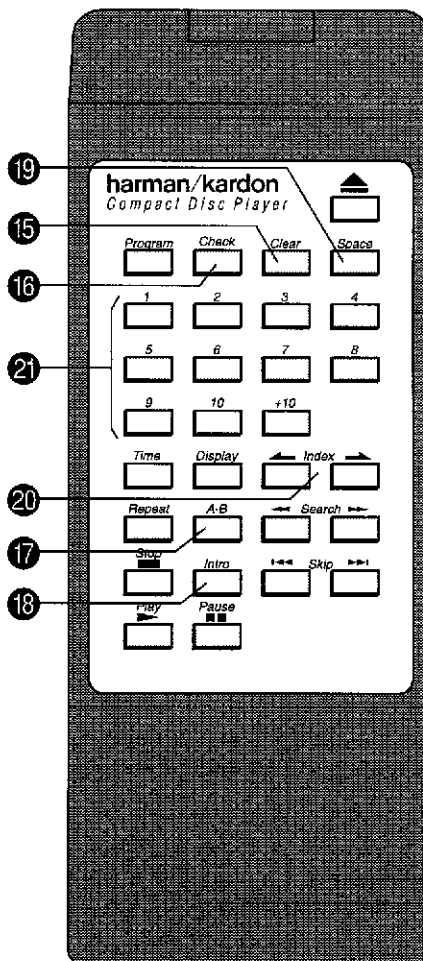

**17 A-B button**

This button puts your compact disc player in and out of A-B mode. In A-B mode, the unit will continually play back a "phrase" or section of your disc beginning at point A and ending at point B. (For instructions on repeating a section of a disc, see the Operations section of this manual.) When the unit is in A-B mode, the FUNCTION indicator (5) will display REPEAT A-B.

**18 INTRO button**

This button puts your compact disc player in and out of INTRO SCAN mode. When INTRO SCAN is on and you press PLAY, the unit plays only the first 15 seconds of each track before moving on to the next. Press the button once to turn on INTRO SCAN mode; press again to turn it off and stop the scanning. When the unit is in INTRO SCAN mode, the FUNCTION indicator (5) will display the word INTRO.

**19 SPACE button**

This button puts your compact disc player in and out of SPACE mode. Press the button once to turn on SPACE mode; press again to turn it off. In SPACE mode, the unit inserts 4 seconds of blank space between tracks. This is particularly useful if you are recording music from a compact disc onto a tape. Tape decks with a Music Search feature will be able to use the 4 seconds of space to correctly identify the beginning of each selection on the tape. When the unit is in SPACE mode, the FUNCTION indicator (5) will display the word SPACE.

**20 INDEX buttons**

Some discs contain long selections that may be subdivided into shorter sections (for example, operas). Just as the tracks are marked by the track number, these shorter sections may be marked by index numbers. When you have started playback of the desired track, you can use the INDEX UP and INDEX DOWN buttons to jump to a desired index selection. Each time you press an INDEX button, the INDEX indicator displays the next higher or lower index number. If you continue pressing the button until the indicated index number is higher than the actual number of index selections on the disc, playback will start from the nearest index selection.

**21 Track selection buttons**

This set of buttons (numbered 1 through 10 and +10) enables you to directly select the track you want to play. To select a track with a number higher than 10, press the +10 button, then press the button that will add up to the number of the track you want. For example, to select track 14, press +10, then press 4. If you select a track number that does not exist on your disc, the TRACK indicator will continue to display the number of the last track on the disc. When PROGRAM mode is off, pressing a track button plays the track you select. When PROGRAM mode is on, pressing a track button programs that track into your sequence.

**DISASSEMBLY PROCEDURES****[1] CABINET TOP (124) REMOVAL**

Remove 7 screws (A) and then remove the Cabinet Top (124).

**[2] FRONT PANEL ASSEMBLY (AA)REMOVAL**

1. Remove the Cabinet Top (124), referring to the previous step [1].
2. Disconnect the connector with lead wires (JL401) from connectors (CN201) on the Main P. C. Board (PCB-1).
3. Remove lead wire (W401) from the Main P. C. Board (PCB-1).
4. Remove 6 screws (B) and then remove the Front Panel Assembly (AA) with the Front P. C. Board (PCB-2).
6. Remove 9 screws (C) and then remove the Front P. C. Board (PCB-2) from the Front Panel Assembly (AA).

**[3] MAIN P. C. BOARD (PCB-1) REMOVAL**

1. Remove the Cabinet Top (124), referring to the previous step [1].
2. Disconnect the connector with lead wires (LCN113, LCN114, LCN115 and LCN117) from connectors (CN113, CN114, CN115 and CN117) on the Main P. C. Board (PCB-1).
3. Open the lid of connectors (CN2) on the Main P. C. Board (PCB-1), then disconnect the lead wires (JL1 and JL2).
4. Remove 9 screws (E), then remove the Main P. C. Board (PCB-1)

**[4] POWER SUPPLY P. C. BOARD (PCB-5) REMOVAL**

1. Remove 6 screws (G) and four washers (212).
2. Disconnect lead wires (TM1 and TM2) on the Power Supply P. C. Board (PCB-5).
3. Open the lid of connectors (CN2) on the Main P. C. Board (PCB-1), then disconnect the lead wires (JL1 and JL2).
4. Slide back the Power Supply P. C. Board (PCB-5) to disconnect power switch shaft from the Front Panel Assembly (AA) and remove.

**[5] CD PLAYER MECHANICAL ASSEMBLY (104) REMOVAL**

1. Remove the Cabinet Top (124), referring to the previous step [1].
2. Disconnect the connector with lead wires (LCN113, LCN114, LCN115 and LCN117) from connectors (CN113, CN114, CN115 and CN117) on the Main P. C. Board (PCB-1).
3. Remove 3 screws (F) and then remove the CD Player Mechanical Assembly (104) backward.

## DISASSEMBLING THE CD PLAYER MECHANICAL ASSEMBLY

### [6] DISC TRAY (1) REMOVAL

1. Remove the Cabinet Top (124), referring to the previous step [1].
2. Connect the Power cord and turn on the power by pressing the Power switch.
3. Open the Disc Tray (1) by pressing the Open/Close button.
4. With the Disc Tray (1) opened as it is, pull out the power plug.
5. Push the Disc Tray (1) by hand to slide it in once.
6. Loosen the 2 screws (H) and then slide out the Disc Tray (16) by hand.

### [7] OPTICAL PICK-UP (57) REMOVAL

1. Remove the CD Player Mechanical Assembly (104), referring to the previous step [5].
2. Remove 4 screws (I) and then remove the Disc Motor, Pick-up and Slide Motor Assembly (13) from the CD Player Mechanical Assembly (104).

3. Remove gear (58) by gently pressing at its base, to release it and pull it out of the Disc Motor, Pick-up and Slide Motor Assembly (13).
4. Slide the sled shaft (51) towards the disc motor and at the same time open sled shaft stop (J). Gently slide the sled shaft (51) out of the Disc Motor, Pick-up and Slide Motor Assembly (13).
5. Remove the Optical Pick-Up (57) from the Disc Motor, Pick-up and Slide Motor Assembly (13).

### [8] SLIDE MOTOR (60) REMOVAL

1. Unsolder the terminals of the Disc and Slide Motors, then remove the Motor P. C. Board (61).
2. Remove 2 screws (k) and then remove the Slide Motor (60).

## POWER CORD REPLACEMENT (FOR SERVICE ENGINEERS OTHER THAN NORTH AMERICA)

in order to prevent fire or shock hazard when replacing the power cord, follow the procedure below to replace the part with the standard supply parts.

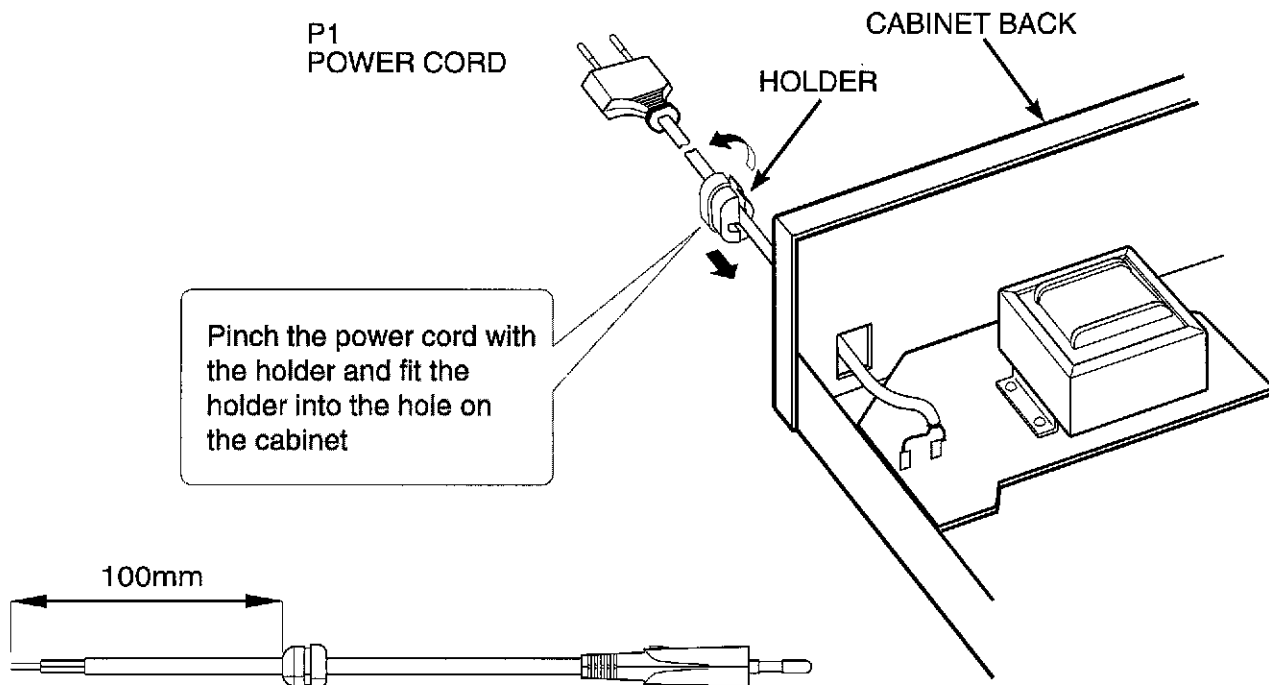



# ADJUSTMENT PROCEDURE

## 1. Instruments required

- DC voltmeter
- Oscilloscope (3 or more modes, 100MHz, input select DC range)
- Jitter meter
- Test disc: EIAJ CD-1

## 2. Adjustment points

2-1 Adjusting screw layout for CD player mechanical assembly.

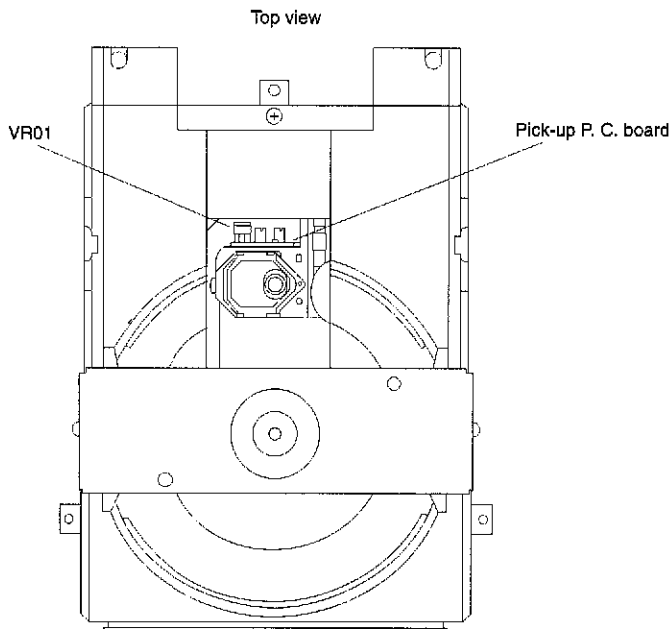

2-2 VR and test point layout for main P.C. board.

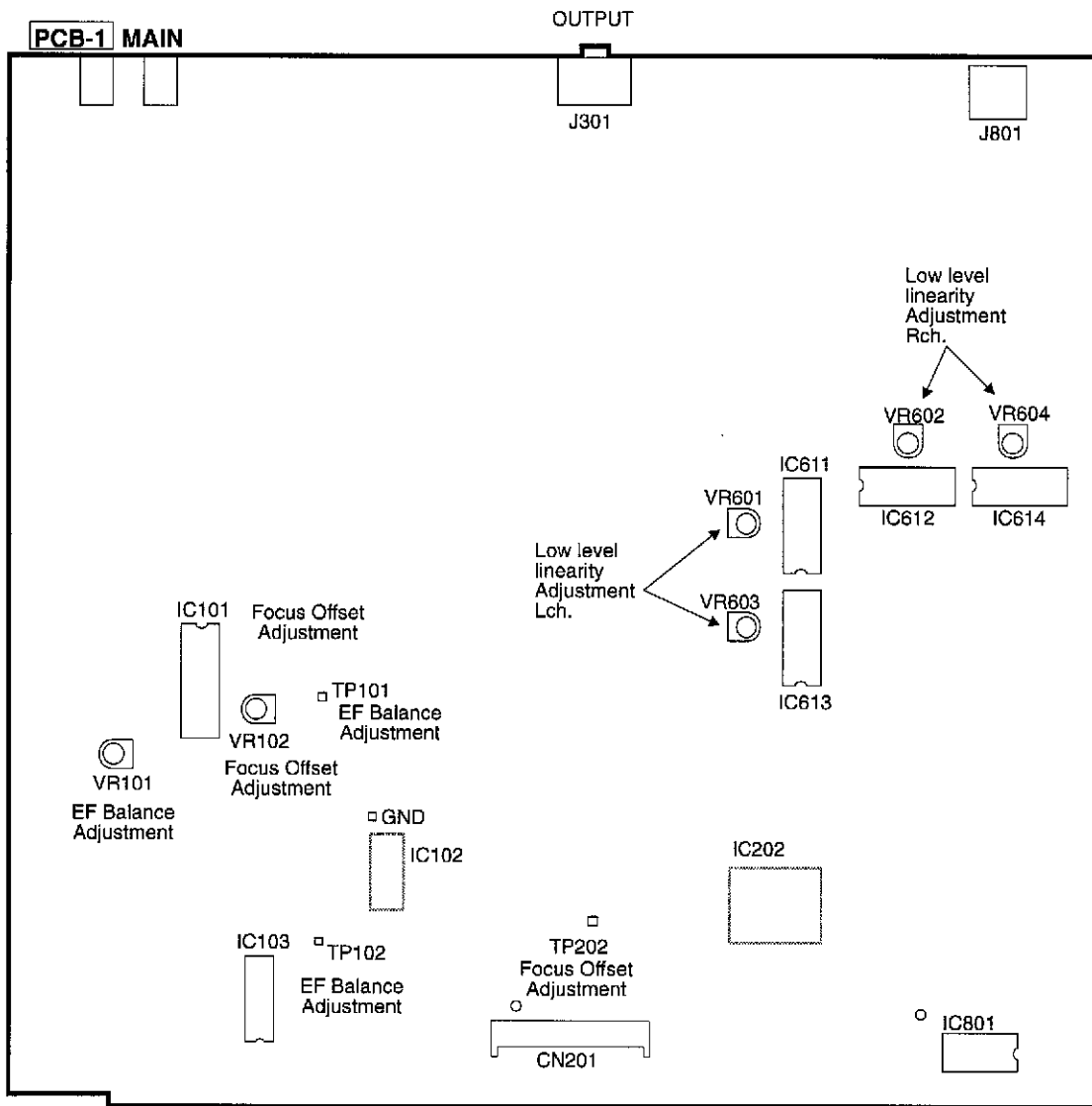

ADJUSTMENT POINT

### 3. Optical Pick-up Laser Power Adjustment

The specified value for adjustment varies with the type of the pick-up in use. Obtain the voltage value according to the following procedure.

- (a) Read the current value on the label of the pick-up P.C. board.
- (b) Using the amperage of the current and the following equation, calculate the voltage value. When the current is 44.1mA;  $V=0.0441A \times 22=0.9702V$
- (1) Connect the DC voltmeter to both ends of R101.
- (2) Insert EIAJ CD-1 test disc and place the unit in the Play mode.
- (3) Adjust VR01 in the pick-up P.C. board to the voltage obtained in step (b) above.

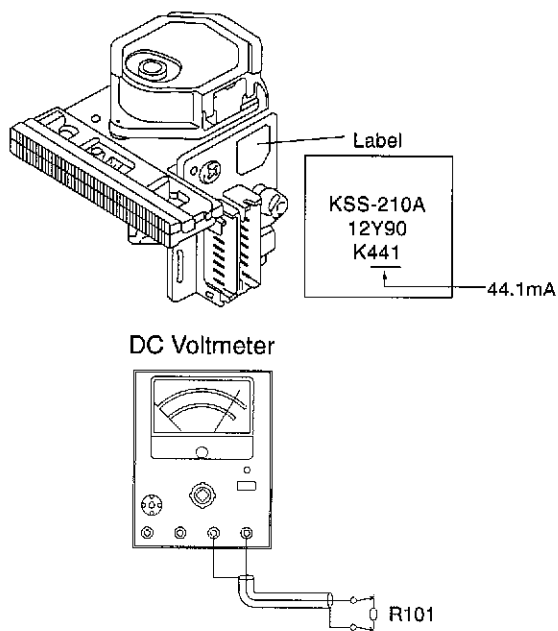

### 4. EF Balance Adjustment

- (1) Connect the oscilloscope (0.5V/div, 5msec./div, DC mode) to TP101 and GND. Short-circuit TP401 and GND.
- (2) Insert EIAJ CD-1 test disc and place the unit in the Play mode.
- (3) Adjust VR101 so that the amplitude above and below the zero DC line becomes equal (Amplitude A = Amplitude B).

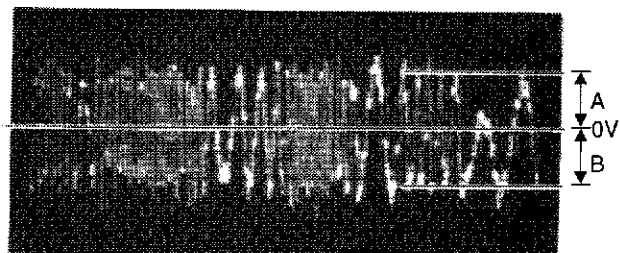
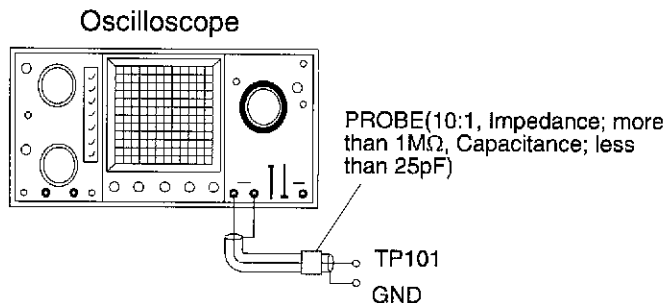

A=B

(approx. 1.5Vp-p)

### 5. Focus Offset Adjustment

- (1) Connect the Jitter meter to TP201 and GND.
- (2) Insert EIAJ CD-1 test disc and place the unit in the Play mode.
- (3) Adjust VR102 until the jitter for optimum sensitivity.

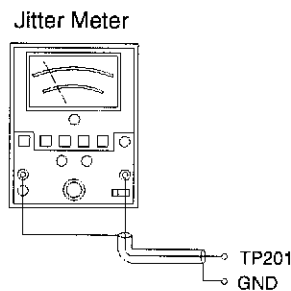

### 6. Jitter Inclination Confirmation

- (1) Connect the Jitter meter (sigma range) to TP201 and GND.
- (2) Insert EIAJ CD-1 test disc and place the unit in the Play mode.
- (3) Confirm the jitter meter reading is less than 30ns.

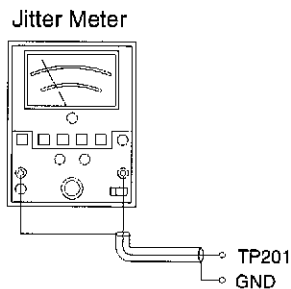

# Troubleshooting

When a problem occurs, first check the pick-up lens for dirt and each connector for tight and secure connection. If the problem persists after checking both of these items, use the following check procedures.

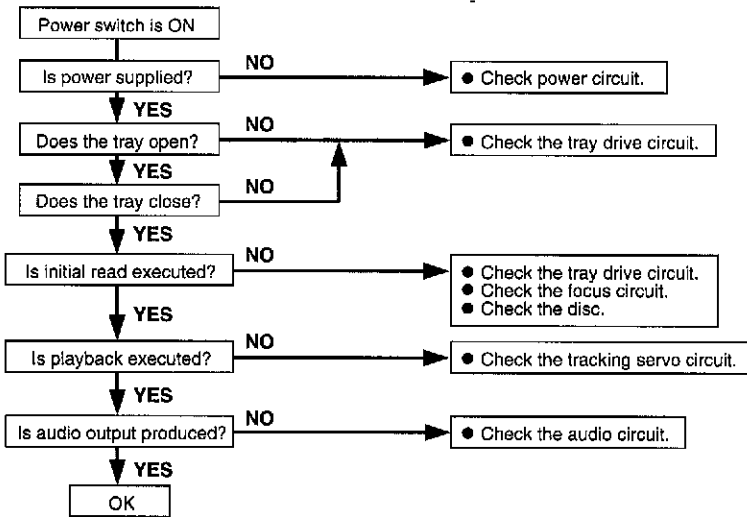

(1) When Multi Display fails to light properly.

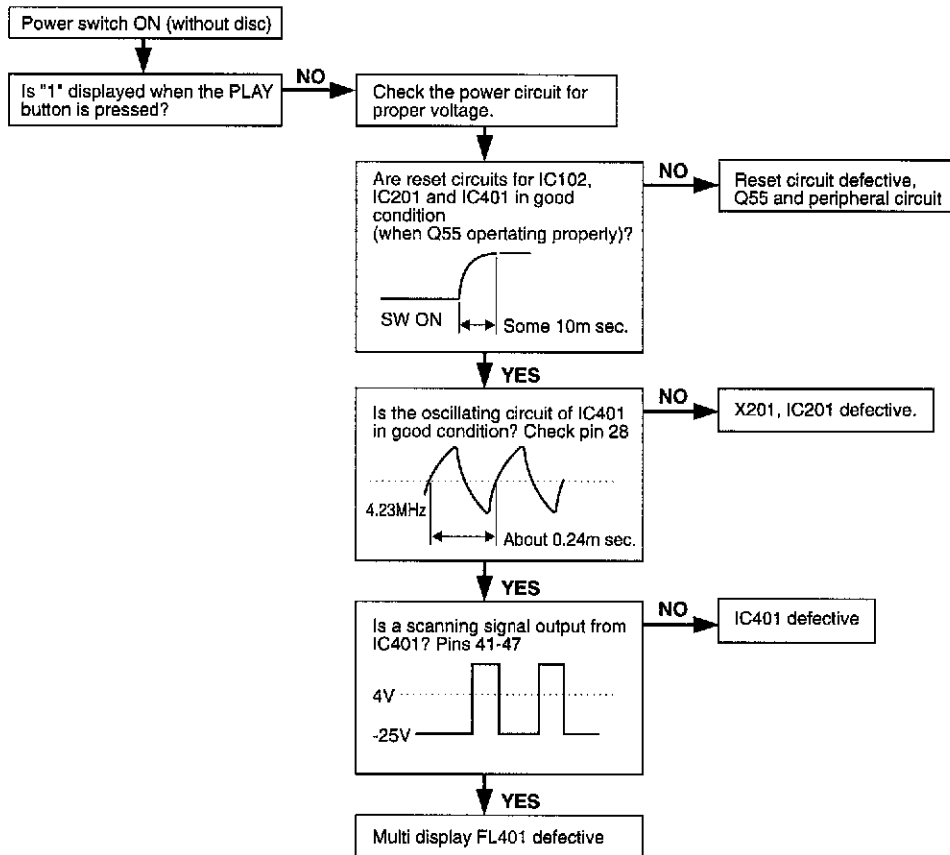

When a problem occurs, first check the pick-up lens for dirt and each connector for tight and secure connection. If the problem persists after checking both of these items, use the following check procedures.

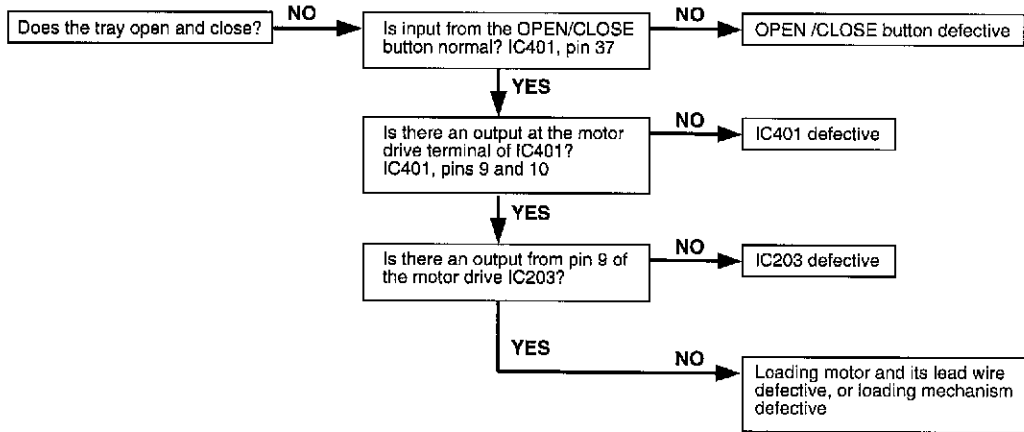

(3) When initial read cannot be executed.

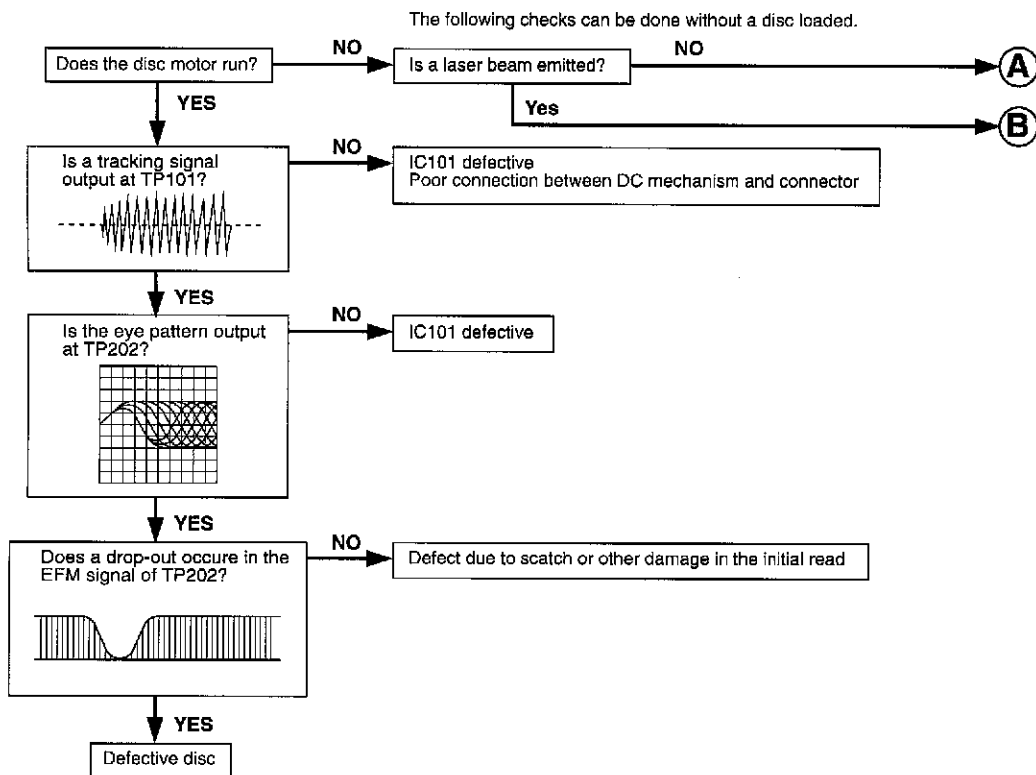

**A** When Laser not emitted.

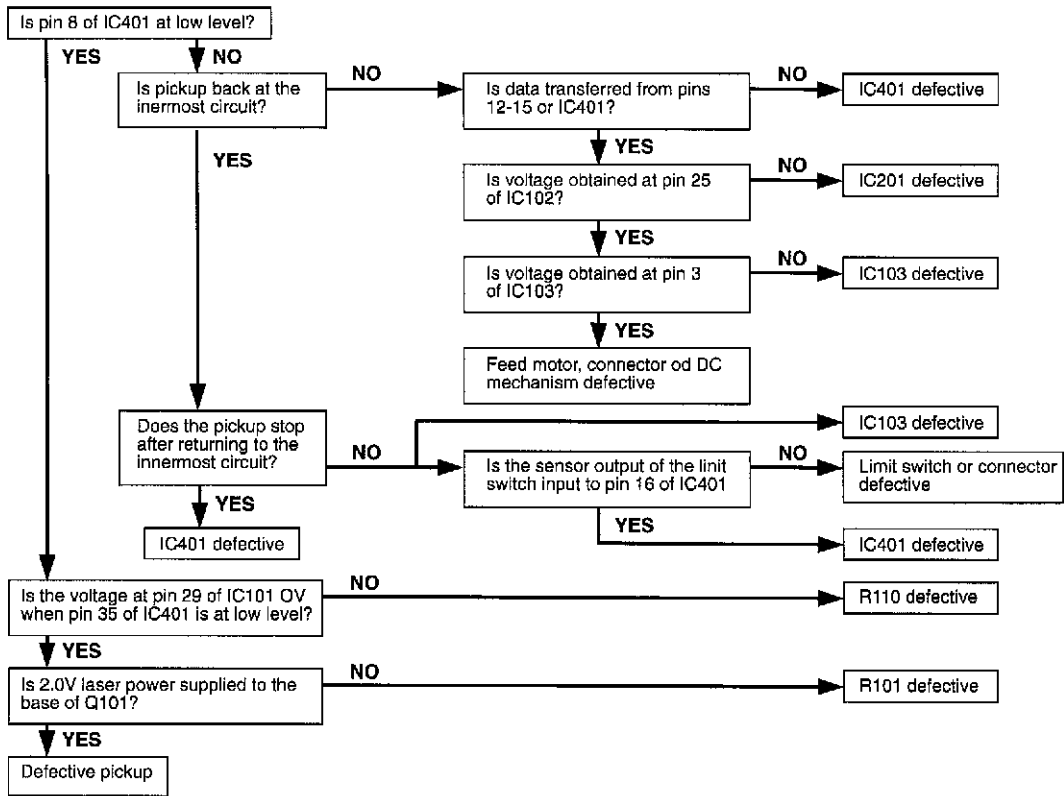

**B** When Laser is emitted.

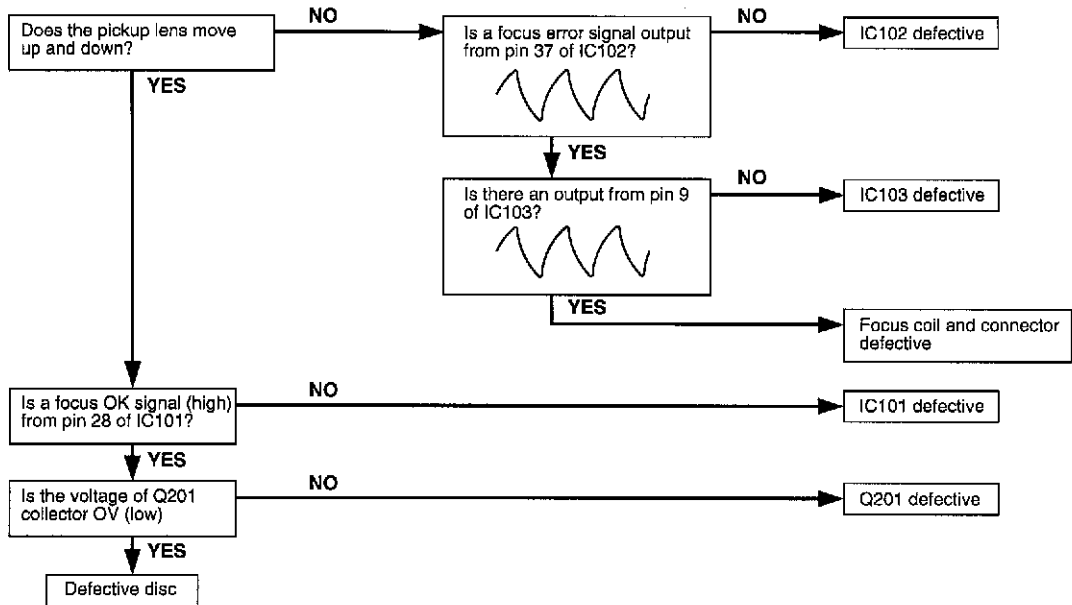

When there is no audio output

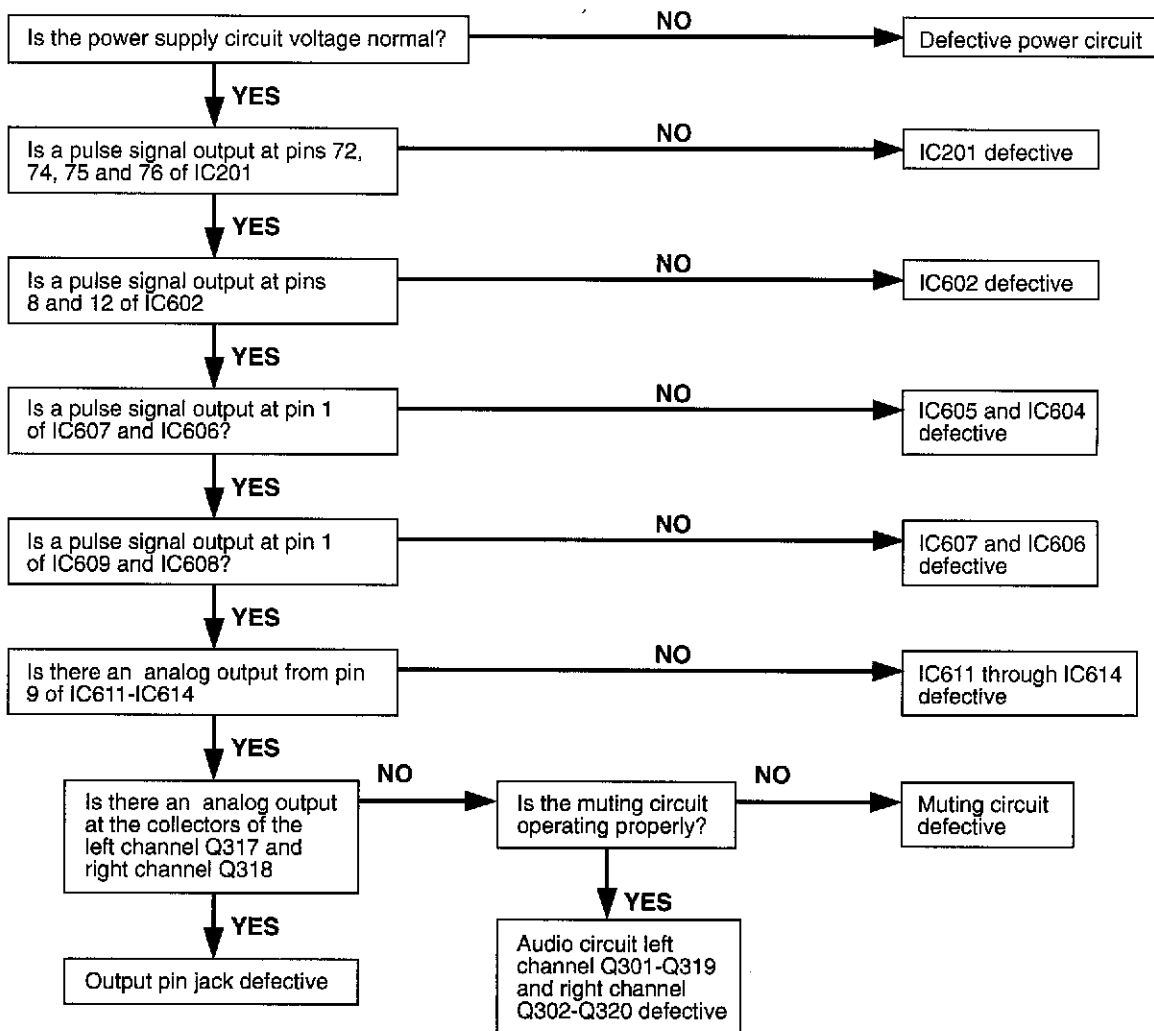

IC NUMBER	TERMINAL NUMBER	PORT NAME	TERMINAL CODE	I/O	OUTLINE OF FUNCTIONS
IC101	1	RFI		I	RF summing amp. input terminal.
	2	RFO		O	RF summing amp. output terminal.
	3	RF-		I	RF summing amp. return input terminal.
	4	P/N		I	Laser diode P/N select terminal.
	5	LD		O	APC LD amp. output terminal.
	6	PD		I	APC PD amp. input terminal.
	7	PD1		I	RF I-V amp. (1) invert input terminal.
	8	PD2		I	RF I-V amp. (2) invert input terminal.
	9	VC		-	GND terminal.
	10	F		I	F I-V amp. invert input terminal.
	11	E		I	E I-V amp. invert input terminal.
	12	EO		O	E I-V amp. output terminal.
	13	EI		I	E I-V amp. return input terminal.
	14	VR		O	DC voltage output terminal.
	15	CC2		I	DEFECT signal input terminal.
	16	CC1		O	DEFECT signal output terminal.
	17	VEE		-	Negative power terminal.
	18	FE BIAS		I	Focus error amp. bias terminal.
	19	FE		O	Focus error amp. output terminal.
	20	TE		O	Tracking error amp. output terminal.
	21	DEFECT		O	DEFECT comparator output terminal.
	22	MIRR		O	MIRR comparator output terminal.
	23	CP		I	MIRR hold capacitor connect terminal.
	24	CB		I	DEFECT hold capacitor connect terminal.
	25	DGND		-	GND terminal.
	26	ASY		I	Auto asymmetry control input terminal.
	27	EFM		O	EFM comparator output terminal.
	28	FOK		O	Focus OK comparator output terminal.
	29	LD ON		I	Laser diode on/off select terminal.
	30	VCC		-	Positive power terminal
IC102	3	TE IN	Pre amp. input	I	Tracking error signal input terminal.
	4	TC IN	Pre amp. input	I	Track cross signal input terminal.
	5	MR	Pre amp. input	I	Mirror detected signal input terminal.
	6	Jump Flag	Mi-com I/O	O	Outputs "H" under jump function.
	8	HF OK	Pre amp. input	I	HF OK signal input terminal.
	9	HFD	Mi-com I/O	O	"1" indicates that MR input is "1" and track servo loop is off (TS OFF, JF, JR).
	10	DATA OUT	Mi-com I/O	O	Inner condition output changed by command modes.
	11	JP1	Mi-com I/O	I	1 track jump control signal. Usually "H".
	12	MSD	Mi-com I/O	I	Serial data input terminal (LSB first, 8-bit data).
	13	MLA	Mi-com I/O	I	Latch signal of serial data from mi-com to servo IC.
	14	MCK	Mi-com I/O	I	Clock signal of serial data from mi-com to servo IC. Receives data on leading edge.
	15	ACLR	Mi-com I/O	I	All clear input (clear inner registers and flip-flops by "L" signal).
	18	Bias	Power supply	O	Vcc/2 bias power supply output when single-pole power supply is used.
	19	COM	Power supply	I	Common terminal. Connect to GND when double-pole power supply is used and to BIAS when single-pole power supply is used.
	20	GND	Power supply	I	GND terminal.
	21	VEE	Power supply	I	Negative power terminal. Connect to GND when single-pole power supply is used.
	22	C*FSR	Focus supply	-	Connect capacitor which determines time constant of focus search waveform.
	23	I-Ref	Power supply	I	Terminal for connecting resistor for setting current value of reference current source.
	24	Vcc	Power supply	I	Positive power terminal.
	25	SS OUT	Slide servo	O	Operation amplifier SS output.
	26	SS -	Slide servo	I	Operation amplifier SS reverse input.
	27	SS +	Slide servo	I	Operation amplifier SS non-reverse input.
	28	TS OUT	Track servo	O	Operation amplifier TA output.
	29	TS -	Track servo	I	Operation amplifier TA reverse input.
	30	TG2	Track servo	-	Track gain select switch TG2 output. Set to open or common level.
	31	TS +	Track servo	I	Operation amplifier TA non-reverse input.
	32	TG1	Track servo	-	Track gain select switch TG1 output. Set to open or common level.
	33	TE OUT	Track servo	O	Operation amplifier TE output.
	34	TE -	Track servo	I	Operation amplifier TE reverse input.
35	FSR IN	Focus servo	I	Focus search voltage level detector input.	
36	FG	Focus servo	-	Focus gain select switch FG output. Set to open or common level.	
37	FS OUT	Focus servo	O	Operation amplifier FA output.	
38	FS -	Focus servo	I	Operation amplifier FA reverse input.	
39	FS +	Focus servo	I	Operation amplifier FA non-reverse input.	

IC NUMBER	TERMINAL NUMBER	PORT NAME	TERMINAL CODE	I/O	OUTLINE OF FUNCTIONS
IC103	1	+VIN 1		I	Positive input terminal 1 for amp. 1.
	2	-VIN 1		I	Negative input terminal 1 for amp. 1.
	3	OUT 1		O	Output terminal 1.
	4	OUT 2		O	Output terminal 2.
	5	-VIN 2		I	Negative input terminal 2 for amp. 2.
	6	+VIN 2		I	Positive input terminal 2 for amp. 2.
	7	+VIN 3		I	Positive input terminal 3 for amp. 3.
	8	-VIN 3		I	Negative input terminal 3 for amp. 3.
	9	OUT 3		O	Output terminal 3.
	10	NC		-	
	11	NC		-	
	12	Vcc		-	Positive power supply.
IC201	1	EMP		O	Emphasis code output. Emphasis = "1"
	2	PWM1		O	Disc motor drive PWM output 1. -
	3	PWM2		O	Disc motor drive PWM output 2. +
	4	DOTX		O	Digital output.
	5	ACRCY		I	Channel status clock input.
	6	TEST1		I	Test mode select input.
	7	DOBSSEL		I	Output data bit select.
	8	DASEL1		I	D/A converter interface select input 1.
	9	DASEL2		I	D/A converter interface select input 2.
	10	DASEL3		I	D/A converter interface select input 3.
	11	DASEL4		I	D/A converter interface select input 4.
	12	MSD		I	Microcomputer interface serial data input.
	13	MCK		I	Microcomputer interface shift clock input.
	14	MLA		I	Microcomputer interface data latch clock input.
	15	ACLR		I	Microcomputer interface register clear input.
	16	HFD		I	Play signal absence signal input.
	17	HF		I	Play signal input.
	18	IREF		I	Detection/PLL circuit reference current input.
	19	TLC		O	Slice level control output.
	20	LPF		I/O	PLL loop filter connection terminal.
	21	LOCK/DRD		O	Synchronous/low disc rotate status output.
	22	SYCLK		O	Frame synchronous status output.
	23	VDD2		I	5V power supply used for Detection/PLL circuit analog area only.
	24	DRD		O	Low disc rotate status output.
	25	EFFK		O	EFM frame clock output.
	26	SCINT		O	Subcode Q interrupted signal output.
	27	SQRO		O	Subcode Q register output.
	28	SQRCK		I	Subcode Q register data shift clock input.
	29	SCOR		O	Subcode synchronous signal output.
	30	CRCF		O	Subcode Q CRC check result output.
	31	SCCK		I	Shift clock input for serial subcode data output.
	32	VSS2		I	GND terminal.
	33	SCOE2		I	Subcode parallel output channel P to S enable input.
	34	SCOE1		I	Subcode parallel output channel T to W enable input.
	35	SBCW		O	Subcode channel W output.
	36	SBCV		O	Subcode channel V output.
	37	SBCU		O	Subcode channel U output.
	38	SBCT		O	Subcode channel T output.
	39	SBCS		O	Subcode channel S output.
	40	SBCR		O	Subcode channel R output.
	41	SBCQ		O	Subcode channel Q output.
	42	SBCP		O	Subcode channel P output.
	43	RAS	RT1	O	Row address strobe signal output.
	44	TEST 2	TEST 2	I	Test mode select input.
	45	RDB2	RT2	I/O	External memory data I/O 2.
	46	NC		-	
	47		RT3	I/O	External memory data I/O 1.
	48		RT4	I/O	External memory data I/O 4.
	49		RT5	O	Column address strobe signal output.
	50		RT6	I/O	External memory data I/O 3.
	51		RT7	O	Write enable signal output.
	52		RT8	I	External memory address output 7.
	53		RT9	O	External memory address output 1.
	54		RT10	O	External memory address output 2.



IC NUMBER	TERMINAL NUMBER	PORT NAME	TERMINAL CODE	I/O	OUTLINE OF FUNCTIONS
IC201	55		RT11	O	External memory address output 3.
	56	NC		-	
	57		RT12	O	External memory address output 4.
	58		RT13	O	External memory address output 5.
	59		RT14	O	External memory address output 6.
	60	RT15	RT15	O	External memory address output 0.
	61	EST2		O	Error status 2.
	62	EST1		O	Error status 1.
	63	VDD1		I	5V power supply.
	64	DOFK		O	OSC frame clock output.
	65	F5CK		O	Clock output 44.1kHz.
	66	C846		O	Clock output 8.4672MHz.
	67	C423		O	Clock output 4.2336MHz
	68	CKSEL		I	1/2 divider input.
	69	DFSEL		O	1/2 divider output.
	70	XI		I	Crystal oscillator input.
	71	XO		O	Crystal oscillator output.
	72	DO1		O	D/A converter serial data output.
	73	VSS1		I	GND terminal.
	74	DSCK		O	D/A converter data shift clock output.
75	LRCK		O	D/A converter left/right clock output.	
76	DO2		O	Dual D/A converter serial data output.	
77	WDCK		O	D/A converter word clock.	
78	DLRCK		O	D/A converter left/right clock output.	
79	APTL		O	D/A converter deglitch clock L.	
80	APTR		O	D/A converter deglitch clock R.	
IC203	1	VSENCE1			
	2	OUT1		O	Output terminal 1.
	3	-VIN1		I	Negative input 1.
	4	+VIN1		I	Positive input 1.
	5	VEE			Negative power supply.
	6	+VIN2		I	Positive input 2.
	7	-VIN2		I	Negative input 2.
	8	OUT2		O	Output terminal 2.
	9	VSENCE2			
	10	Vcc			Positive power supply.
IC401	1	VCC			Positive power supply.
	2	P65		I/O	
	3	P64		I/O	
	4	P63		I/O	
	5	P62		I/O	
	6	P61		I/O	
	7	P60		I/O	
	8	P27	I/O port	I/O	Disc tray open direction driving output.
	9	P26	I/O port	I/O	Disc tray close direction driving output.
	10	P25	I/O port	I/O	
	11	P24	I/O port	I/O	Serial data output.
	12	P23	I/O port	I/O	Serial data output.
	13	P22	I/O port	I/O	Data latch clock output.
	14	P21	I/O port	I/O	
	15	P20	I/O port	O	
	16	P37	OUT PORT	O	Display output i.
	17	P36	OUT PORT	O	Display output g.
	18	P35	OUT PORT	O	Display output f.
	19	P34	OUT PORT	O	Display output e.
	20	P33	OUT PORT	O	Display output d.
	21	P32	OUT PORT	O	Display output c.
	22	P31	OUT PORT	O	Display output b.
	23	P30	OUT PORT	O	Display output a.
	24	P53			
	25	P52			
	26	CNVSS			Usually connected to VSS.
	27	RESET		I	Reset input.
	28	XIN	CLOCK IN	I	Clock input.
	29	XOUT	CLOCK OUT	O	Clock output.
	30	XCIN	CLOCK IN	I	Serial data input.

IC NUMBER	TERMINAL NUMBER	PORT NAME	TERMINAL CODE	I/O	OUTLINE OF FUNCTIONS
IC401	31	XCOU	CLOCK OUT	O	Clock output.
	32	VSS			Power supply.
	33	∅		O	Timing output.
	34	P57			
	35	P56			
	36	P55			
	37	P54			
	38	VP		I	Pull down voltage input.
	39	P51			
	40	P50			
	41	P17	OUT PORT	O	Laser diode control output.
	42	P16	OUT PORT	O	Display output 7.
	43	P15	OUT PORT	O	Display output 6.
	45	P13	OUT PORT	O	Display output 4.
	46	P12	OUT PORT	O	Display output 3.
	47	P11	OUT PORT	O	Display output 2.
	48	P10	OUT PORT	O	Display output 1.
	49	P07	I/O PORT	I/O	Serial data input.
	50	P06	I/O PORT	I/O	Frame synchronous state output.
	51	P05	I/O PORT	I/O	Low disc rotate state output.
	52	P04	I/O PORT	I/O	Sub-code synchronous signal output.
	53	P03	I/O PORT	I/O	Sub-code Q check.
	54	P02	I/O PORT	I/O	Sub-code channel Q output.
	55	P01	I/O PORT	I/O	Interrupt input.
	56	P00	I/O PORT	I/O	
	57	P47			
	58	P46			
	59	P45			
	60	P44			
	61	P43			
	62	P42			
	63	P41			
	64	P40			
	IC602	1	1A		
2		1Y			Out.
3		2A			In.
4		2Y			Out.
5		3A			In.
6		3Y			Output.
7		GND			Ground.
8		4Y			Out.
9		RA			In.
10		5Y			Out.
11		5A			In.
12		6Y			Out.
13		6A			In.
14		Vcc			Supply voltage.
IC603	1	A			Serial input.
	2	B			Serial input.
	3	QA			Output.
	4	QB			Output.
	5	QC			Output.
	6	QD			Output.
	7	GND			Ground.
	8	CP			Clock pulse.
	9	MR			Master reset clear.
	10	QE			Output.
	11	QF			Output.
	12	QG			Output.
	13	QH			Output.
	14	Vcc			Supply voltage.

IC NUMBER	TERMINAL NUMBER	PORT NAME	TERMINAL CODE	I/O	OUTLINE OF FUNCTIONS
IC611 through IC614	1	-Vs		-	Negative analog power supply.
	2	DIG GND		-	Digital ground.
	3	+Vi		-	Positive logic power supply.
	4	NC		-	
	5	CLK		I	Clock input.
	6	LEC		I	Latch enable control input.
	7	DATA		I	Data input.
	8	-Vi		-	Negative logic power supply.
	9	VOUT		O	Voltage output.
	10	RF		I	Feedback resistor.
	11	SJ		I	Summing junction.
	12	ANA GND		-	Analog ground.
	13	IOUT		O	Current output.
	14	MSB ADJ		-	MSB adjustment terminal.
	15	V POT		-	Potentiometer terminal.
	16	+Vcc		-	Positive analog power terminal.
IC801	1	1Y		O	Output terminal 1.
	2	1A		I	Input terminal 1.
	3	1B		I	Input terminal 1.
	4	2Y		O	Output terminal 2.
	5	2A		I	Input terminal 2.
	6	2B		I	Input terminal 2.
	7	GND			Ground terminal.
	8	3A		I	Input terminal 3.
	9	3B		I	Input terminal 3.
	10	3Y		O	Output terminal 3.
	11	4A		I	Input terminal 4.
	12	4B		I	Input terminal 4.
	13	4Y		O	Output terminal 4.
	14	VCC			Power supply terminal.

## CIRCUIT DESCRIPTION

### 1. APC CIRCUIT

A semiconductor laser is used as the light source for the optical pickup. As the output from the semiconductor laser changes radically with changes in temperature, a circuit must be provided to stabilize this output. For this purpose, a monitor diode which detects the optical output of the laser diode is used in the semiconductor laser.

As the laser diode emits light from its bonded surface, light is emitted both in front and behind. The light emitted behind is monitored with the monitor diode installed on its rear surface, and the optical output is thus controlled. The light emitted in front becomes the light source for the pickup.

Fig. 1 shows the APC circuit.

When the temperature rises and the optical output decreases, the monitor diode current ( $I_S$ ) decreases, the electric potential of IC101 pin 5 rises, the base current of the driving transistor increases, and the laser diode current increases. This causes the reduced optical output to return to its former level.

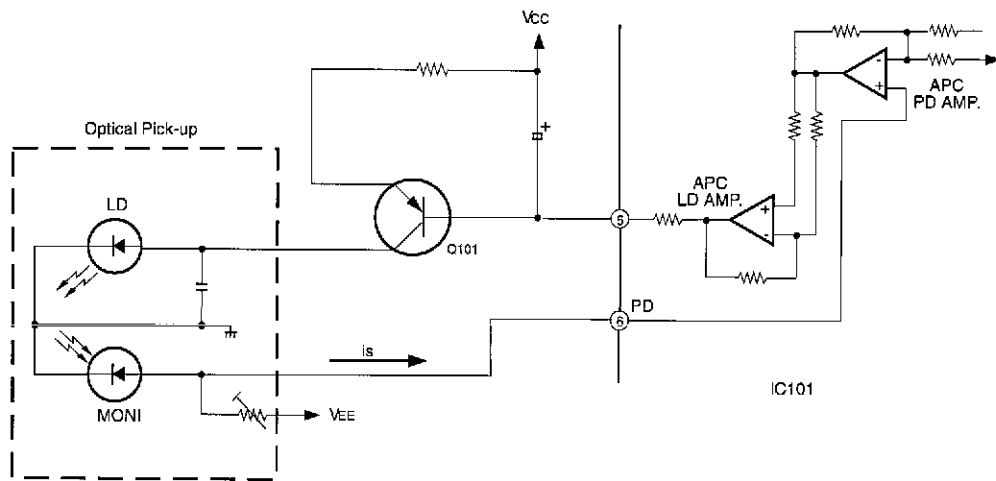

Fig. 1

### 2. FOCUS SERVO

#### 2-1. Optical Pickup

This set employs a three-beam optical pickup comprised of six division photodiodes, A through F as shown in Fig. 2. The four photodiodes (A through D) at the center provide focus error detection by using their property to allow the beam to focus into a round image only at a certain point.

The sums of outputs from diagonal two elements of four division photodiodes (A+C and B+D) are compared by the differential amplifier in IC101 to detect the shape of the beam image.

The remaining two diodes (E and F) provide tracking error detection by means of sub-beam spots.

#### 2-2. Focus error detecting operation

The reflected laser beam from a disc is polarized 90 with the beam-splitter and sent to the cylindrical lens. The beam passed through this cylindrical lens is then sent to the four division photodiodes and focuses into an image whose shape varies with the distance between the disc and the objective lens. Such change in the beam shape causes the current flowing from photodiodes to vary.

Shown in Fig. 3 is the principle of the focus error detection.

The currents from the photodiodes (A+C and B+D) are applied to pins 7 and 8 of IC101 and converted to voltage by RF 1-V amplifiers (1) and (2) included in IC101.

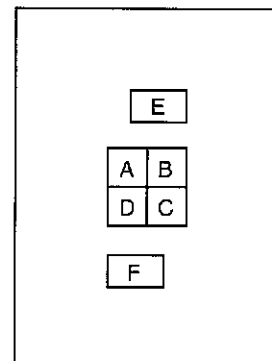

Three spotted (six-division) photo diodes

Fig. 2

Fig. 3

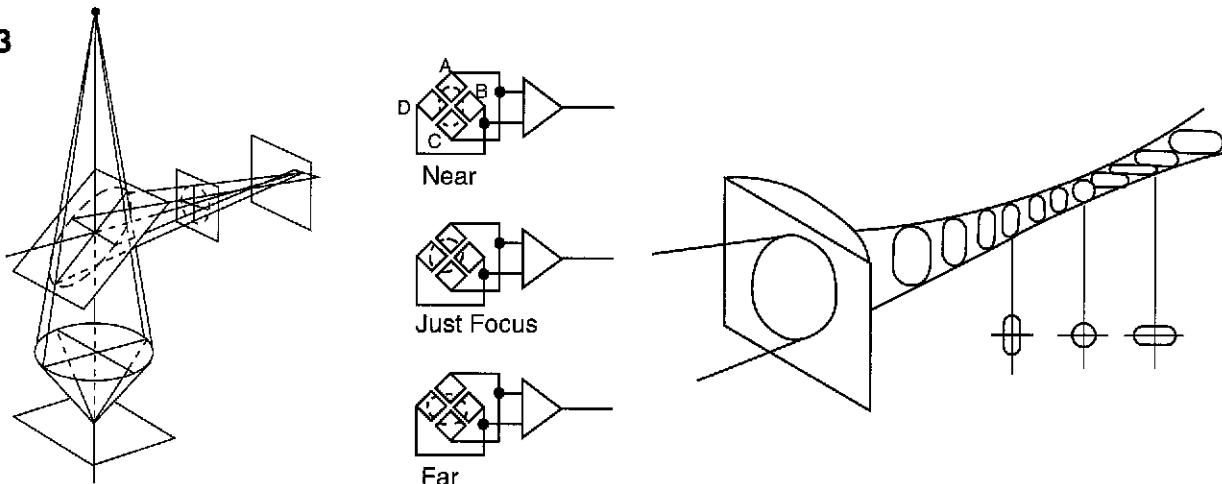

**2-3. Focus servo control operation**

The focus error signal, after being converted to voltage by the RF 1-V amplifier, is transmitted to the operation amplifier in the IC and output from pin 19. When the disc to objective lens distance is in just focus, the beam forms a true round. In this state, the beams applied to four elements in four division photodiodes become equal and thus the output provided then is 0 (zero). When the disc to objective lens distance is too close (near focus), the beam is reflected divergently to form an oval in crosswise direction. In this state the outputs provided from photodiodes A and C are higher than those from B and D, resulting in negative (-) output voltage. On the other hand, when the distance is too far (far focus), the beam is reflected convergently to form an oval in longitudinal direction. Then the outputs from photodiodes B and D are higher, resulting in positive (+) output.

The output voltage (focus error signal) from pin 19 of IC-101 passes through IC-102, in from pin 39 and out from pin 37, and IC103, in from pin 7 out from pin 9 as shown in Fig. 4. It is amplified in each IC and fed to the focus coil which then drives the objective lens of the pickup.

**Fig. 4**

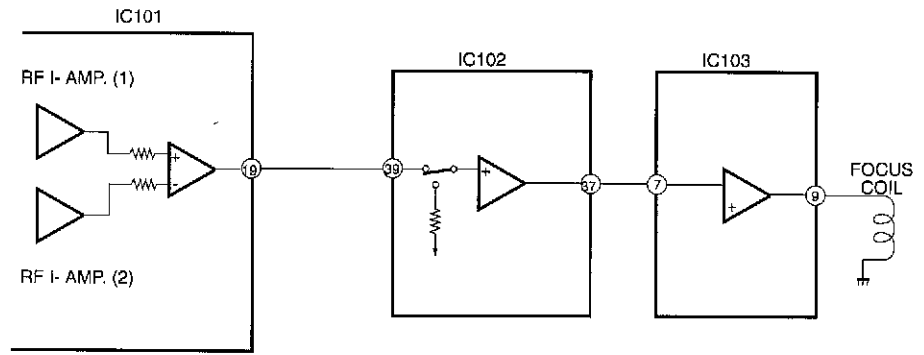

**2-4. Tracking error detection**

Fig. 5 shows the principle of the tracking error detection system which employs the three beam system.

The laser beam is divided into the main beam and two sub-beams by diffraction grating and they are arranged on one line. The center line connecting these three beams has a slight offset angle against the main beam. The main beam is received by photodiodes A, B, C and D and two sub-beams by E and F respectively.

Fig. F-A shows the on-track state. As both auxiliary beams 1 and 2 are slightly on the track in this state, the outputs of photodiodes E and F are equal and the tracking signal is 0 (zero). When the track is shifted to the left (Fig. 5-B), the auxiliary beam 1 is off the pit. This allows more light to be received by photodiode E, resulting in positive (+) tracking signal output. On the other hand, when the track is shifted to the right (Fig. 5-C), the amount of light received by the photodiode F increases, resulting in negative (-) tracking signal output. And these extreme signals are detected as tracking error signals.

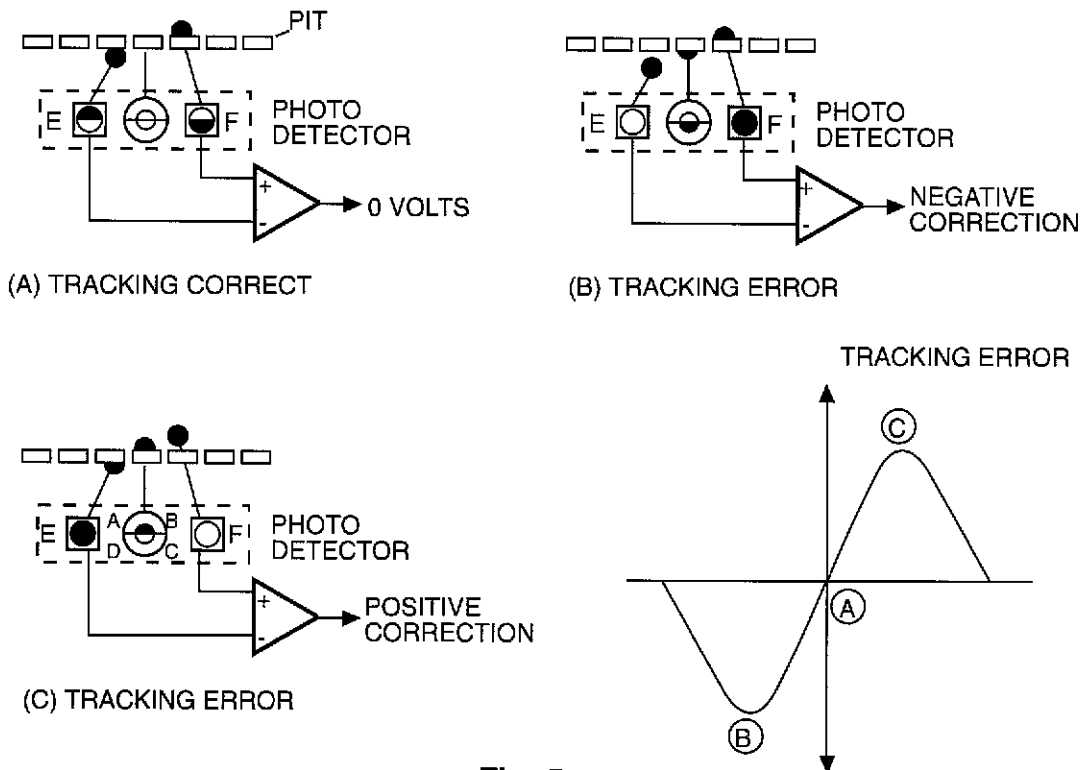

**Fig. 5**

**2-5. Tracking servo control operation**

When a tracking error signal is detected by photodiodes E and F, it is fed to pins 11 and 10 of IC101 respectively as shown in Fig. 6. In IC101, the signal is converted into voltage by the E I-V amplifier and F I-V amplifier, transmitted to the tracking error amplifier and output through pin 20. While it passes through IC102, in from pin 3 and out from pin 28, and IC103, in from pin 6 and out from 4, it is amplified in each IC and sent to the tracking coil to adjust pickup so that the amount of track shift is reduced as closely to none as possible.

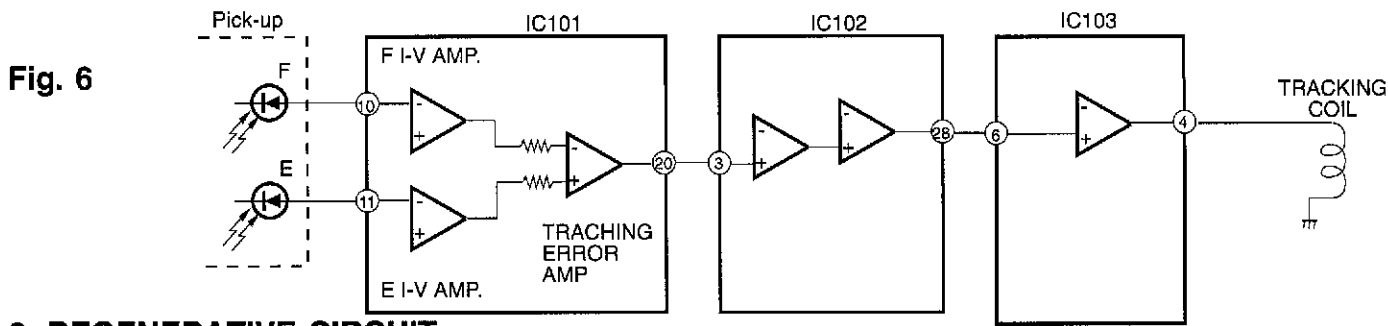

**3. REGENERATIVE CIRCUIT**

**3-1. RF circuit**

The currents from photodiodes (a, b, c and d) are fed to IC101 through pins 7 and 8 and converted to voltage by RF I-V amplifiers (1) and (2) respectively there, added by the RF summing amplifier and output from pin 2 as a signal. As it is sent to pin 17 of IC201, it can be checked at the test point (TP202) provided on its way by means of the eye pattern check (as shown in Fig. 7).

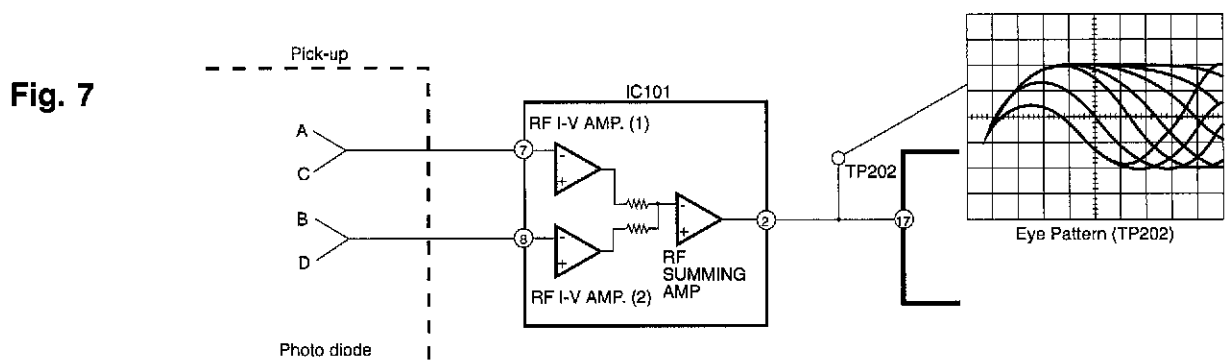

**3-2. EFM demodulation, error correction, serial/parallel conversion**

EFM demodulation, error correction, digital filtering, and serial/parallel conversion are performed by the internal circuitry of IC201. The eye-pattern signals from pin 2 of IC101 are sent to pin 17 of IC201, then demodulated from 14 bits to 8 bits by EFM readjustment. At the same time any error, if found, is corrected (CIRC) and the signals are sent to the D/A converter interface. After that, they are output from pins 72, 74, 75 and 76 of IC201 and fed to the RLS (Real-Time Linear Smoothing) module (as shown in Fig. 8).

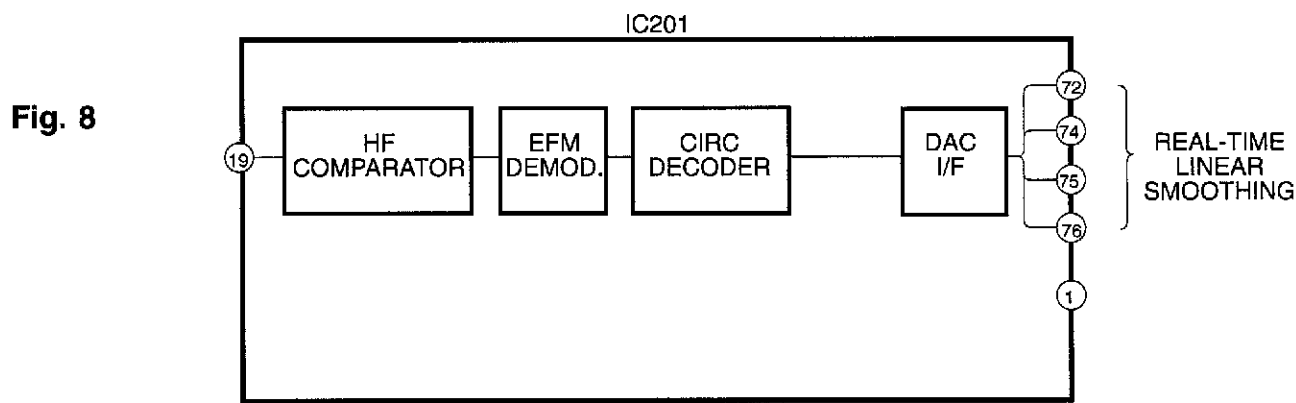

## 4. REAL-TIME SMOOTHING MODULE

The output of pins 72, 74, 75 and 76 of IC201 drives the IC602 Hex Inverter and the IC603 8-bit shift register. IC602 and IC 603 drives IC605, IC607 and IC609 (for the left channel) and IC604, IC606 and IC608 (for the right channel). The signals from IC605 drives IC611 directly, and passes through IC607 and IC609 before driving IC613. This results in the timing of the signal to pin 7 of IC611 being ahead of the signal to pin 7 of IC613. In the same way, the timing of the signal to pin 7 of IC612 is ahead of the signal to pin 7 of IC614. IC611, IC612, IC613 and IC614 are 18 bit linear D/A converters operating on the R-2 R, or ResistorLadder, Principle. The signals from pin 10 of IC611, IC612, IC613 and IC614 are sent to the Comparator/Integrator and Summing Amplifier (as shown by Fig 9).

THE RLS SYSTEM (BLOCK DIAGRAM)

Fig. 9

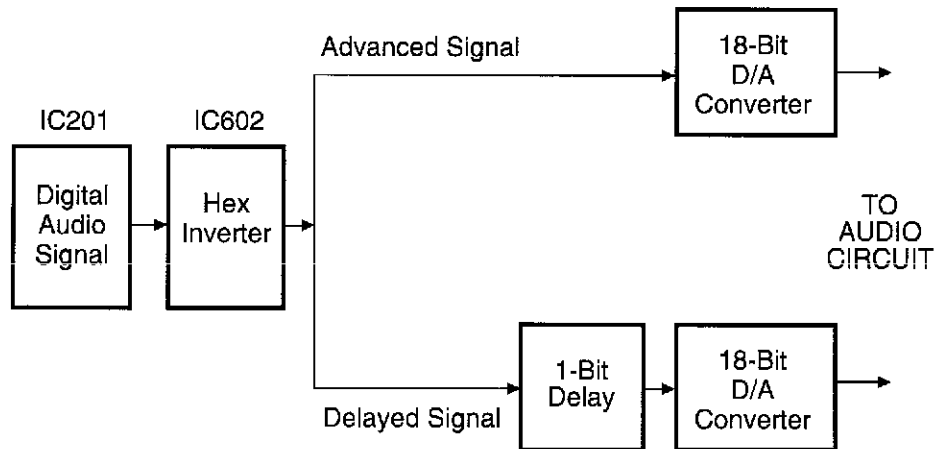

## 5. AUDIO CIRCUIT

### 5-1. Comparator/Integrator and Summing Amplifier.

Dual-Differential circuits comprising of Q301, Q303, Q305, Q307, Q309 and Q311 with capacitor C309, smoothes out the time difference between IC611 and IC613. The signal is then fed through R329 to the final buffer circuit, Q313 and Q315 (for the left channel). Also Dual-Differential circuits comprising of Q302, Q304, Q306, Q308, Q310, and Q312 with capacitor C310, smoothes out the time difference between IC612 and IC614. The signal is then fed through R330 to the final buffer circuit, Q314 and Q316 (for the right channel). If needed, de-emphasis is applied by turning on Q337 (for the left channel) and Q338 (for the right channel).

### 5-2. Output Amplifier

The left output jacks are driven by an amplifier comprised of Q317 and Q319. The right output jacks are driven by an amplifier comprised of Q318 and Q320. Also Muting is provided by Q331, Q332, Q333 and Q334 (as shown by Fig. 10).

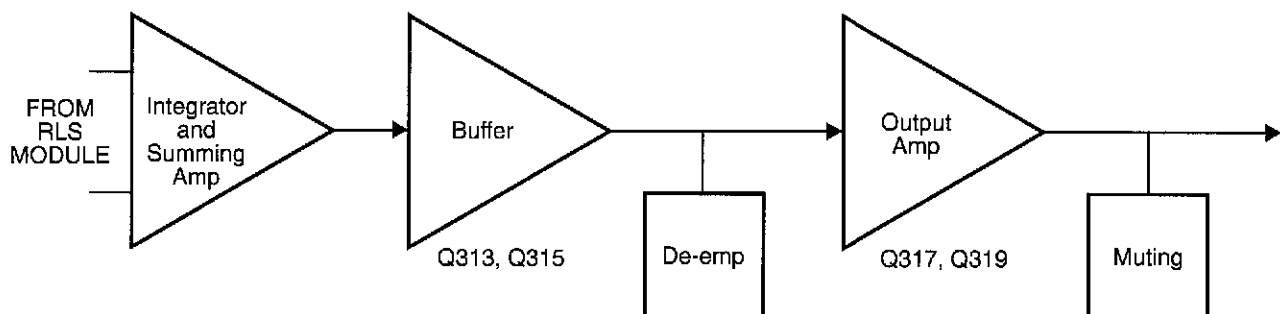
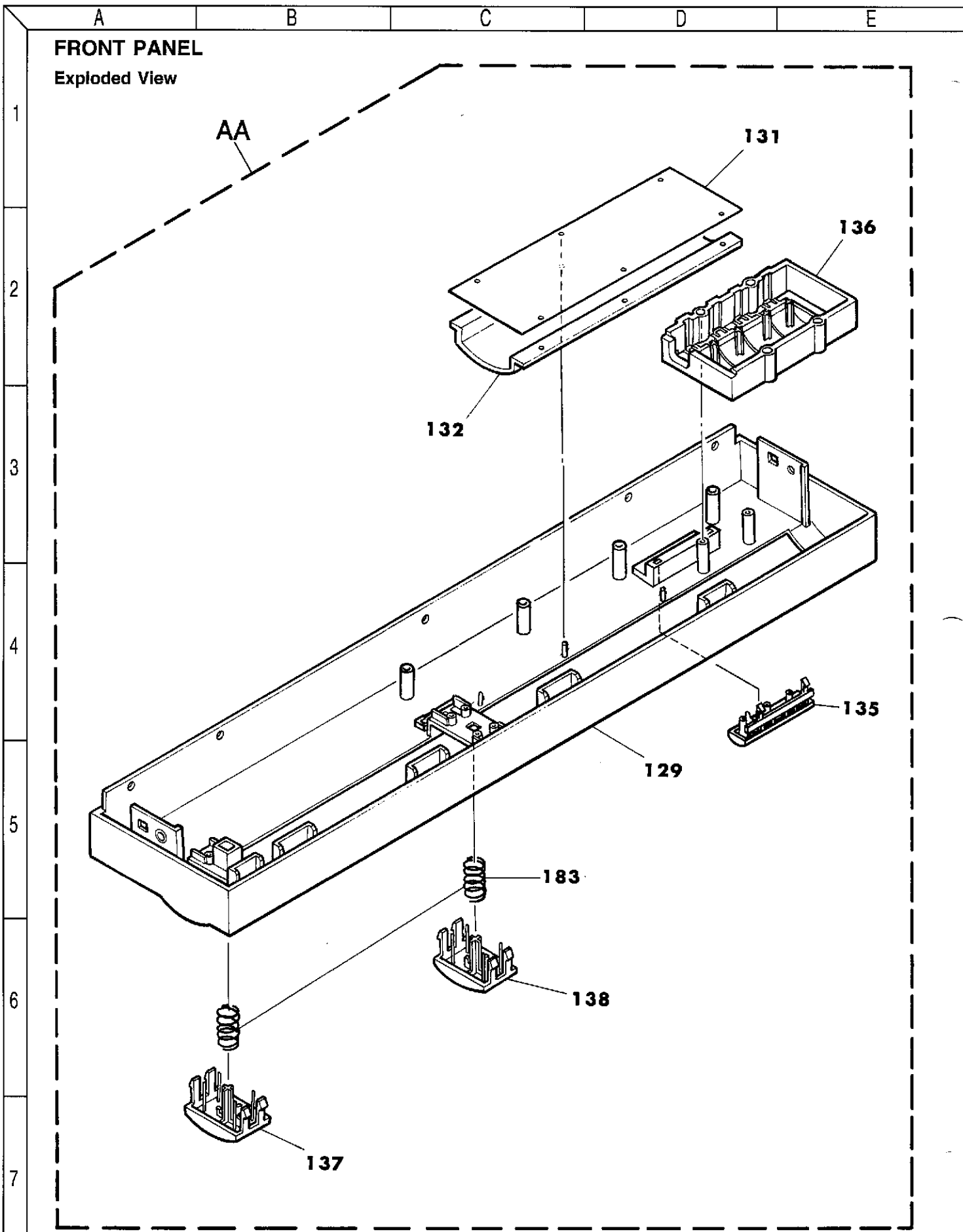

Fig. 10



**FRONT PANEL**

Exploded View

AA

131

136

132

129

135

183

138

137

1

2

3

4

5

6

7



A B C D E

# GENERAL UNIT

Exploded View

1  
2  
3  
4  
5  
6  
7

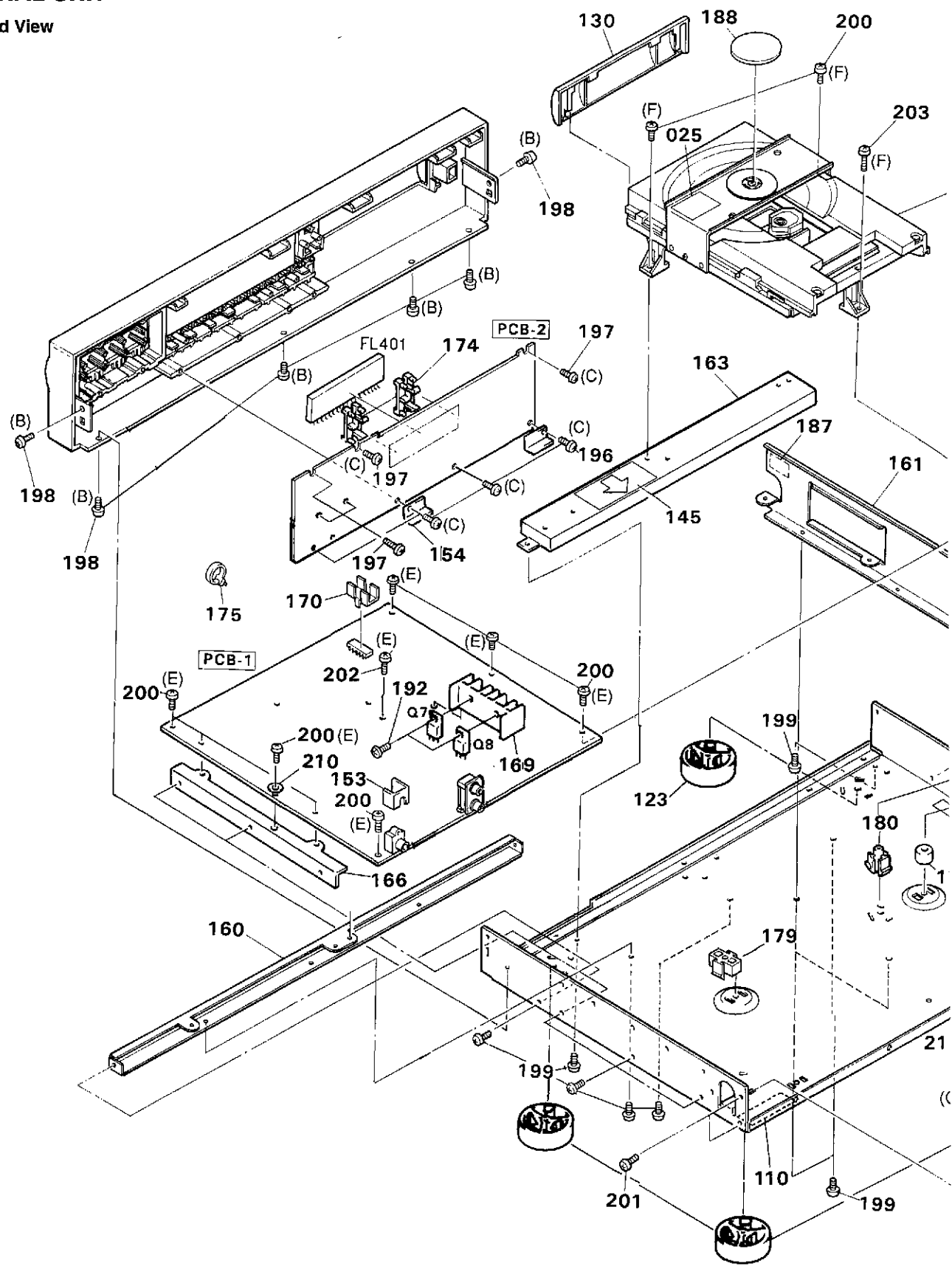

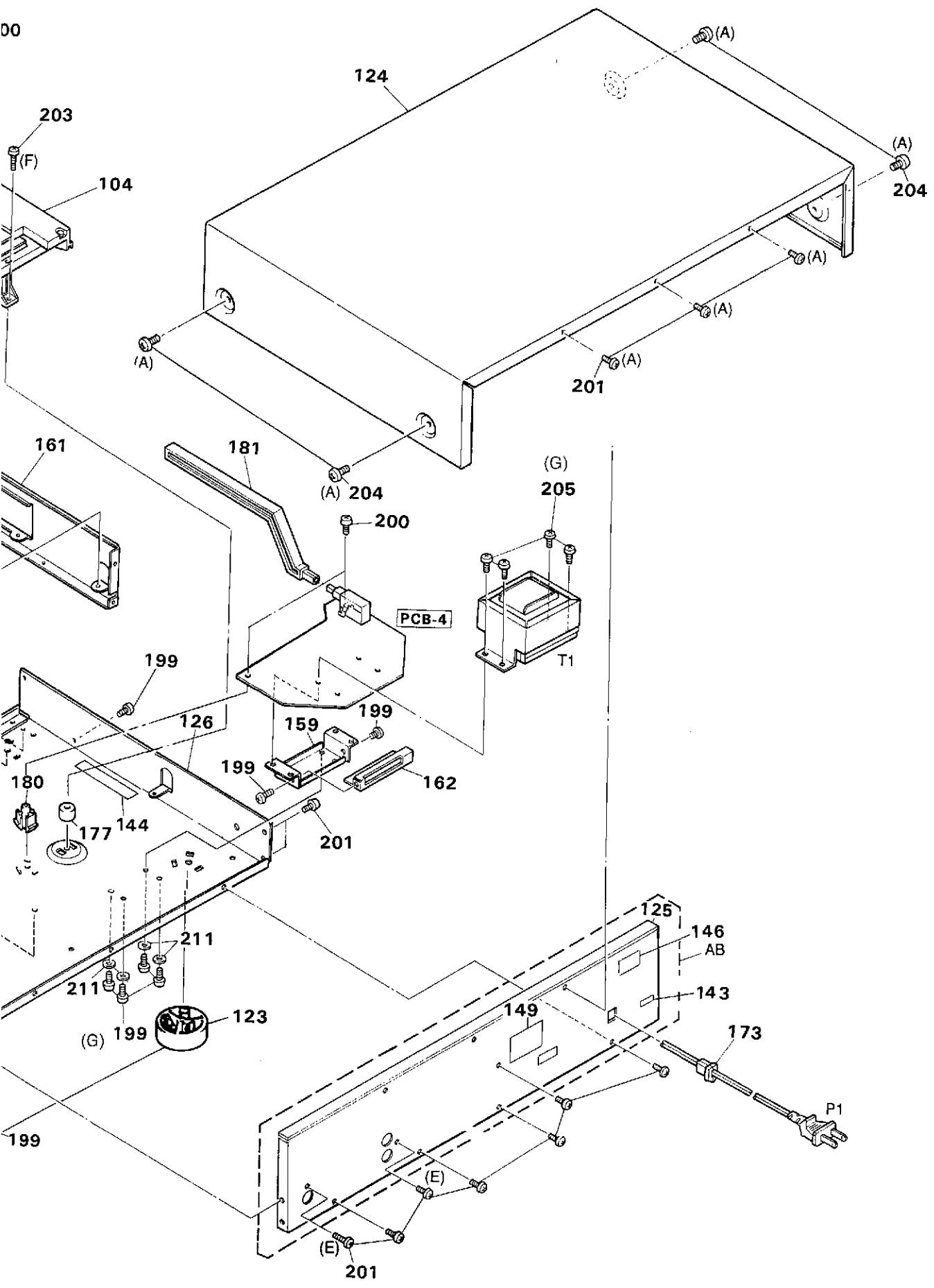

A B C D E

# CD MECHANISM

Exploded View

1  
2  
3  
4  
5  
6  
7

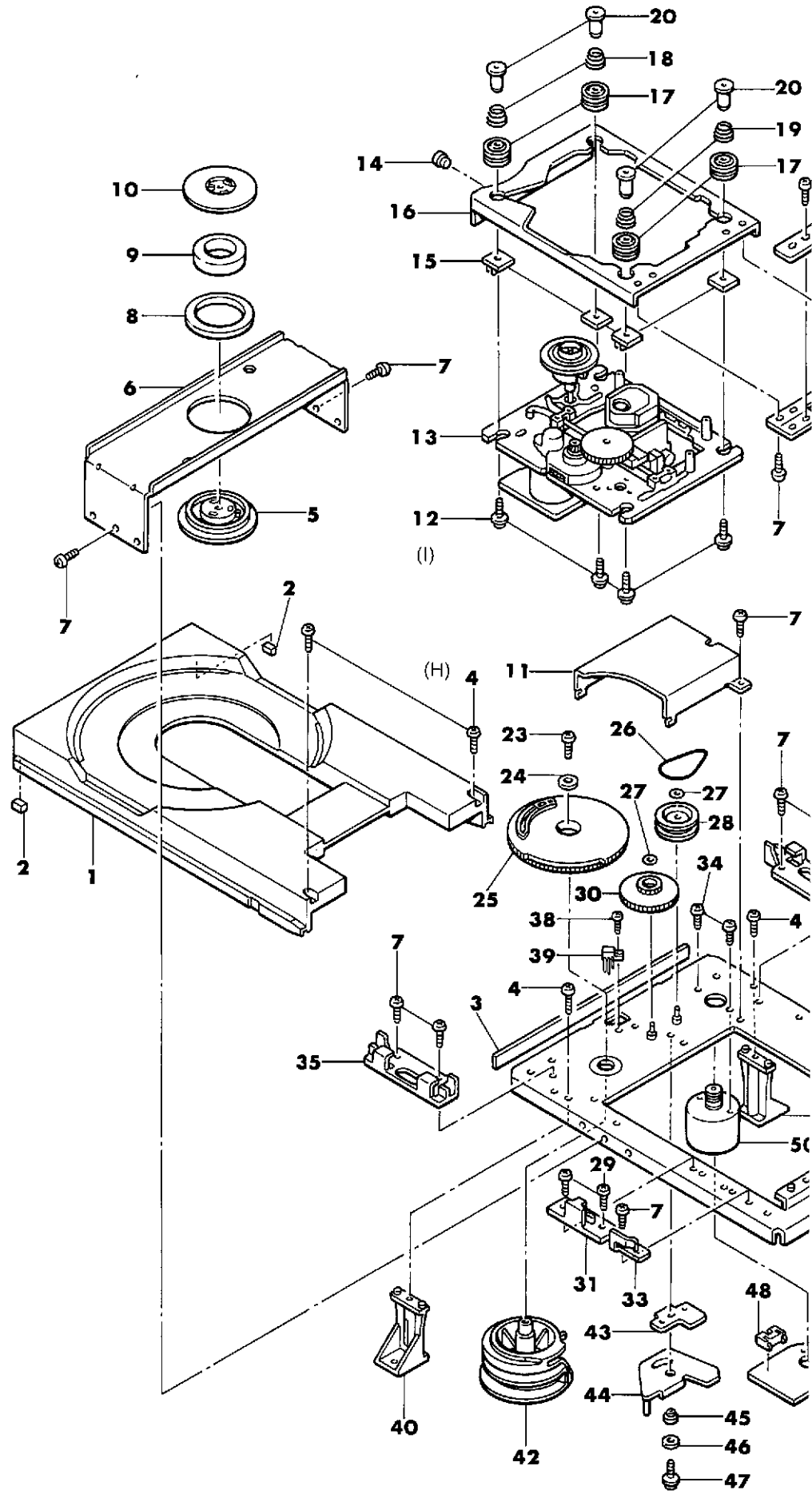

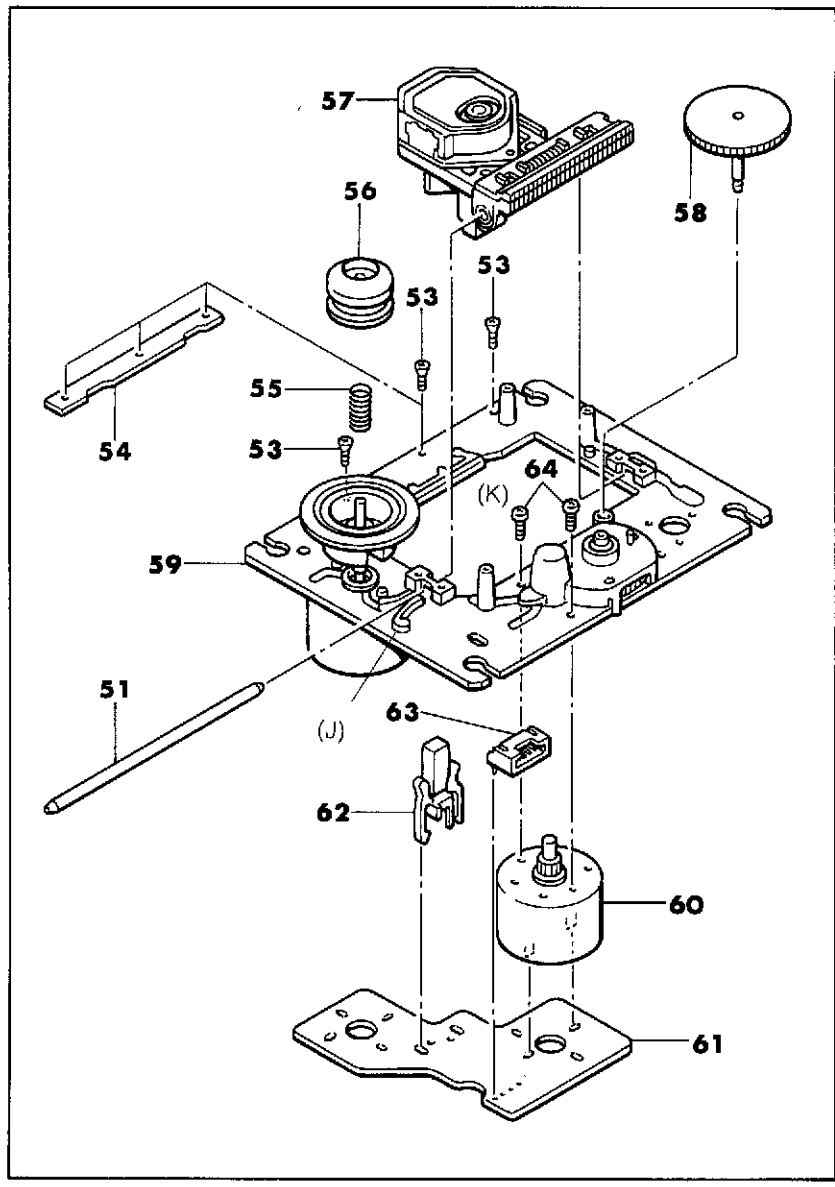
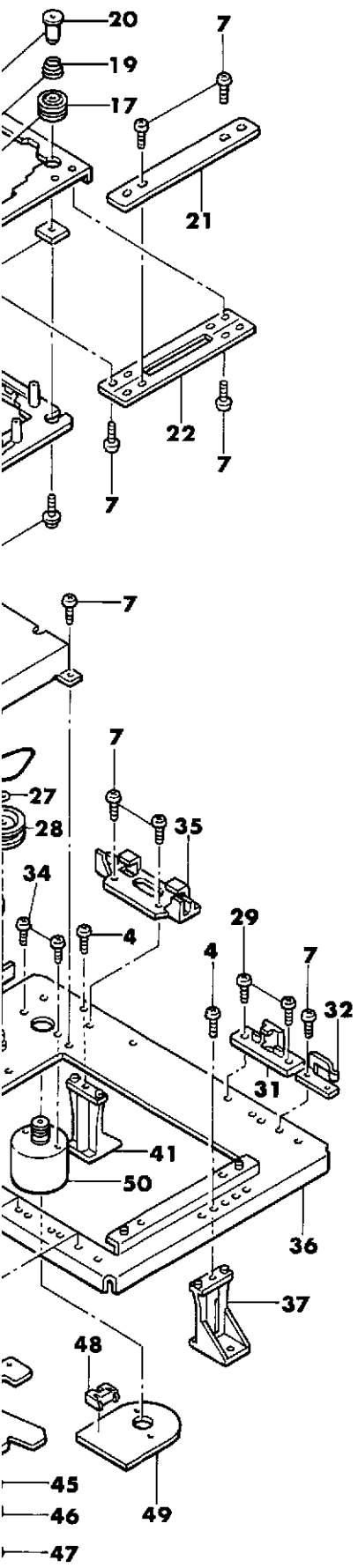

## GENERAL UNIT PARTS LIST

## REF. NO. PART NO.

## DESCRIPTION

REF. NO.	PART NO.	DESCRIPTION	REF. NO.	PART NO.	DESCRIPTION
AA	A442-HD7525C	FRONT PANEL ASSEMBLY <b>BK GB</b>	177	2363-501725	PIPE BOSS, MECHA
AA	A442-HD7525A	FRONT PANEL ASSEMBLY <b>G</b>	179	2360-7018	SPECIAL BOSS, MAIN PCB
AB	A424-HD7525B	CABINET BACK ASSEMBLY <b>G GB</b>	180	2360-7022	SPECIAL BOSS, POWER SUPPLY PCB
AB	A424-HD7525A	CABINET BACK ASSEMBLY <b>BK</b>	181	2601-7187	SHAFT, POWER SWITCH
025	1756-11802	LABEL <b>G GB</b>	183	2651-2101732	SPRING, PUSH BUTTON (X2)
!104	3119-02401	CD MECHA ASSEMBLY	187	2111-1197	FELT
110	1117-78	SERIAL LABEL, SET	188	2111-1422	FELT, MECHA
123	1319-03301	LEG (X4)	192	2327-R0130082	SCREW, BND+ (3x8mm) (X2)
124	1414-14601	CABINET TOP	196	2343-301021	SCREW, CSK T+ (3x10mm) (X4)
125	1424-33025	CABINET BACK <b>BK</b>	197	2347-R0126082	SCREW, BND T+ (2.6x8mm) (X5)
125	1424-33026	CABINET BACK <b>G GB</b>	198	2347-R0130064	SCREW, BND T+ (3x6mm) (X6)
126	1424-29603	CABINET BOTTOM	199	2347-R0130082	SCREW, BND T+ (3x8mm) (X18)
129	1442-28602	FRONT PANEL <b>G GB</b>	200	2347-R0130082	SCREW, BND T+ (3x8) (X12)
129	1442-28601	FRONT PANEL <b>BK</b>	201	2347-R0130084	SCREW, BND T+ (3x8mm) (X14)
130	1452-08302	LID <b>G</b>	202	2347-R0130142	SCREW, BND T+ (3x14mm)
130	1452-08301	LID <b>BK GB</b>	203	2347-R0130162	SCREW, BND T+ (3x16mm)
131	1511-19803	PLATE, FL FILTER	204	2347-R0140084	SCREW, BND T+ (4x8mm) (X4)
132	1532-17502	WINDOW, FRONT	205	2347-R0140102	SCREW, BND T+ (4x10mm) (X4)
135	1662-68202	PUSH BUTTON, DISPLAY/ PROGRAM/TIME <b>BK GB</b>	210	2411-3021	WASHER, PLAIN
135	1662-68201	PUSH BUTTON, DISPLAY/ PROGRAM/TIME <b>G</b>	211	2401-035	WASHER, METAL (X4)
136	1662-52404	PUSH BUTTON, CONTOLS <b>BK GB</b>			
136	1662-52403	PUSH BUTTON, CONTOLS <b>BK GB</b>			
137	1662-52001	PUSH BUTTON, POWER <b>BK GB</b>			
137	1662-52003	PUSH BUTTON, POWER <b>G</b>			
138	1662-52002	PUSH BUTTON, OPEN/CLOSE <b>BK GB</b>			
138	1662-52004	PUSH BUTTON, OPEN/CLOSE <b>G</b>			
143	1341-568	NAME PLATE, PRODUCTION DATE <b>BK</b>			
144	1756-03305	LABEL, LASER CAUTION			
145	1756-09602	LABEL, LASER CAUTION <b>BK</b>			
145	1756-12101	LABEL, LASER CAUTION <b>G GB</b>			
146	1756-CSA	LABEL, CSA <b>BK</b>			
149	1756-11801	LABEL, LASER WARNING LABEL			
153	2216-7203	SHIELD PLATE, COAXIAL JACK			
154	2216-7187	SHIELD PLATE, FRONT PCB (X2)			
159	2219-8262	METAL FITTG, TRANS			
160	2219-8263	METAL FITTG, CABINET BOTTOM			
161	2219-8264	METAL FITTG, CABINET BOTTOM			
162	21219-8282	METAL FITTG, TRANS			
163	2219-8290	METAL FITTG, CD MECHA			
166	2219-8377	METAL FITTG, MAIN PCB			
169	2222-7215	HEAT SINK, Q7, 8			
170	2222-7264	HEAT SINK, IC103			
173	2240-364	HOLDER, AC CORD			
174	2240-7387	HOLDER, FL REAR (X2)			
175	2240-R0101	HOLDER, WIRING (X5)			

## CD MECHANISM PARTS LIST

<u>Ref. No.</u>	<u>Part No.</u>	<u>Description</u>	<u>REF. NO.</u>	<u>PART NO.</u>	<u>DESCRIPTION</u>
1	2-642-156-(02)	TRAY (SP)	49	1-624-793-(21)	PC BOARD, MOTOR
2	2-642-125-(01)	DAMPER (X2)	50	X-2641-336-(1)	MOTOR ASSY (RP)
3	2-642-157-(03)	TAPE, FRONT	51	4-917-565-(01)	SHAFT (S), SLED
4	7-685-547-(19)	SCREW +BTP (3X10mm) (X5)	53	2-641-386-(01)	SCREW (2x5mm), TAPPING (S) (X3)
5	2-642-181-(02)	PULLEY (AU), CHUCKING	54	2-625-625-(01)	REINFORCEMENT (S)
6	2-642-165-(01)	CHASSIS (S), CHUCK	55	2-625-191-(01)	SPRING (S), COMPRESSION
7	7-685-862-(01)	SCREW +BVTT (2.6x6mm) (X13)	56	2-625-187-(01)	RING (LO) (S), CENTER
8	2-642-439-(01)	DAMPER, YOKE	57	8-848-127-(31)	PICK UP KSS-210A (S) (RP)
9	1-452-493-(21)	MAGNET	58	2-625-188-(02)	gear (a) (s)
10	2-642-175-(01)	YOKE (SP), CHUCKING	59	X-2625-317-(1)	CHASSIS ASSY (MT) N, TT
11	2-642-149-(02)	COVER (SP), GEAR	60	X-2625-365-(1)	GEAR ASSY (MT), MOTOR
12	2-642-142-(01)	SCREW, WASHER (X4)	61	1-636-788-(13)	PC BOARD, MOTOR (4P) (S)
13	KSM-2101AAM	DRIVE UNIT	62	1-572-085-(12)	SWITCH, LEAF
14	2-642-169-(02)	ROLLER (SP)	63	1-564-720-(11)	PIN, CONNECTOR 4P
15	2-642-159-(01)	PLATE (T) (SP) (X4)	64	7-621-255-(15)	SCREW +P(2x3mm) (X2)
16	X-2642-105-(2)	CHASSIS ASSY (SP), SUB			
17	2-642-158-(01)	INSULATOR (C) (X4)			
18	2-642-139-(02)	SPRING (A) (X2)			
19	2-642-137-(02)	SPRING (B) (X2)			
20	2-642-160-(02)	SHAFT (T) (SP) (X4)			
21	2-642-170-(01)	RETAINER (SP), HINGE			
22	2-642-164-(01)	HINGE (SP)			
23	7-685-535-(19)	SCREW +BTP (2.6x10mm)			
24	4-812-554-(01)	WASHER			
25	2-642-154-(03)	GEAR(SP), DRIVE			
26	3-653-387-(01)	BELT, LM			
27	3-558-708-(21)	WASHER, STOPPER (X2)			
28	4-913-731-(01)	PULLEY, LOADING			
29	7-685-781-(01)	SCREW +PTT (2X4mm) (X4)			
30	2-642-148-(01)	GEAR (SP), MIDWAY			
31	2-642-162-(03)	HOLDER (REAR) (SP), TRAY (X2)			
32	2-642-147-(02)	GUIDE (LEFT) (SP), TRAY			
33	2-642-146-(02)	GUIDE (RIGHT) (SP), TRAY			
34	7-621-775-(00)	SCREW +B (2.6x3mm) (X2)			
35	2-642-161-(01)	HOLDER (FRONT) (SP), TRAY (X2)			
36	X-2642-106-(2)	CHASSIS ASSY (SP), MAIN			
37	2-642-512-(01)	BOSS (REAR)			
38	7-685-851-(01)	SCREW +BVTT (2x4mm)			
39	1-572-052-(11)	SWITCH, LEAF			
40	2-642-510-(01)	BOSS (RIGHT)			
41	2-642-511-(01)	BOSS (LEFT)			
42	2-642-153-(01)	CAM (SP), CONTROL			
43	2-643-173-(01)	PLATE (SP), LINK			
44	X-2642-109-(1)	LINK ASSY (AU), STOPPER			
45	2-642-133-(02)	BOSS			
46	2-642-172-(01)	SPACER (SP)			
47	7-682-902-(31)	SCREW (2.6x8mm) STPWH			
48	1-564-721-(11)	PIN, CONNECTOR 5P			

**ELECTRICAL PARTS LIST**

**PCB-1 MAIN P.C. BOARD**

**CAPACITORS**

510	C18	5345-227C0962	CAP, MINI ELE 220μ/16V
510	C19	5345-227C0962	CAP, MINI ELE 220μ/16V
509	C20	5345-228C0962	CAP, MINI ELE 2200μ/16V
509	C21	5345-228C0962	CAP, MINI ELE 2200μ/16V
511	C22	5345-107D0962	CAP, MINI ELE 100μ /25V
511	C23	5345-107D0962	CAP, MINI ELE 100μ/25V
530	C31	5354-104593	CAP, MYL .1μ
719	C52	5345-226D0962	CAP, MINI ELE 22μ/25V
718	C53	5345-107B0962	CAP, MINI ELE 100μ/10V
720	C54	5345-106F0962	CAP, MINI ELE 10μ/50V
720	C55	5345-106F0962	CAP, MINI ELE 10μ/50V
722	C56	5354-104593	CAP, MYL .1μ
721	C58	5345-105F0962	CAP, MINI ELE 1μ/50V
719	C59	5345-226D0962	CAP, MINI ELE 22μ/25V
633	C101	5345-107B0962	CAP, MINI ELE 100μ/10V
653	C102	5361-100DCH	CAP, CER 10P
653	C103	5361-100DCH	CAP, CER 10P
653	C104	5361-100DCH	CAP, CER 10P
647	C105	5354-332J1HM	CAP, MYL 3300P
643	C106	5354-333J1HM	CAP, MYL .033μ
643	C107	5354-333J1HM	CAP, MYL .033μ
644	C108	5354-103J1HM	CAP, MYL .01μ
632	C109	5345-476D0962	CAP, MINI ELE 47μ/25V
632	C110	5345-476D0962	CAP, MINI ELE 47μ/25V
632	C111	5345-476D0962	CAP, MINI ELE 47μ/25V
636	C112	5345-474F0962	CAP, MINI ELE .47μ/50V
634	C113	5345-226D0962	CAP, MINI ELE 22μ/25V
641	C114	5354-823593	CAP, MYL .082μ
649	C115	5359-S010J681	CAP, PPP 680P
639	C116	5354-274593	CAP, MYL .27μ
637	C117	5342-105F0951	CAP, ELE BP 1μ/50V
640	C118	5354-104593	CAP, MYL .1μ
645	C119	5354-472J1HM	CAP, MYL 4700P
655	C121	5354-183J1HM	CAP, MYL .018μ
638	C122	5354-184593	CAP, MYL .18μ
646	C123	5354-123J1HM	CAP, MYL .012μ
652	C124	5359-S010J391	CAP, PPP 390P
635	C125	5345-476D0962	CAP, MINI ELE 47μ/25V
636	C126	5345-474F0962	CAP, MINI ELE .47μ/50V
642	C127	5354-563593	CAP, MYL .056μ
632	C128	5345-476D0962	CAP, MINI ELE 47μ/25V
632	C129	5345-476D0962	CAP, MINI ELE 47μ/25V
640	C130	5354-104593	CAP, MYL .1μ
640	C131	5354-104593	CAP, MYL .1μ
640	C132	5354-104593	CAP, MYL .1μ
630	C133	5345-477C0962	CAP, MINI ELE 470μ/16V
630	C134	5345-477C0962	CAP, MINI ELE 470μ/16V
651	C141	5354-102J1HM	CAP, MYL 1000P
600	C201	5354-222J1HM	CAP, MYL 2200P
598	C202	5354-223J1HM	CAP, MYL .022μ
599	C203	5359-S010J471	CAP, PPP 470P
597	C204	5354-154593	CAP, MYL .15μ
595	C206	5345-476B0951	CAP, MINI ELE 47μ/10V
650	C209	5359-S010J471	CAP, PPP 470P
650	C210	5359-S010J471	CAP, PPP 470P
640	C211	5354-104593	CAP, MYL .1μ
654	C212	5361-220JCH	CAP, CER 22P
640	C213	5354-104593	CAP, MYL .1μ
631	C214	5345-107D0962	CAP, MINI ELE 100μ/25V
631	C215	5345-107D0962	CAP, MINI ELE 100μ/25V
596	C217	5353-300534	CAP, MCA 30P
596	C218	5353-300534	CAP, MCA 30P
601	C219	5354-104593	CAP, MYL .1μ
544	C301	5345-227C0962	CAP, MINI ELE 220μ/16V
544	C302	5345-227C0962	CAP, MINI ELE 220μ/16V
544	C303	5345-227C0962	CAP, MINI ELE 220μ/16V
544	C304	5345-227C0962	CAP, MINI ELE 220μ/16V
544	C305	5345-227C0962	CAP, MINI ELE 220μ/16V
544	C306	5345-227C0962	CAP, MINI ELE 220μ/16V
544	C307	5345-227C0962	CAP, MINI ELE 220μ/16V

Ser. No.	Ref. No.	Part No.	Description
544	C308	5345-227C0962	CAP, MINI ELE 220μ/16V
548	C309	5359-8215851	CAP, PPP 820P
548	C310	5359-8215851	CAP, PPP 820P
546	C311	5359-1035851	CAP, PPP .01μ
546	C312	5359-1035851	CAP, PPP .01μ
548	C313	5359-8215851	CAP, PPP 820P
548	C314	5359-8215851	CAP, PPP 820P
545	C317	5345-S06DM227	CAP, MINI ELE 220μ/25V
545	C318	5345-S06DM227	CAP, MINI ELE 220μ/25V
549	C319	5359-1835851	CAP, PPP .018μ
549	C320	5359-1835851	CAP, PPP .018μ
547	C321	5359-8225851	CAP, PPP 8200P
547	C322	5359-8225851	CAP, PPP 8200P
577	C604	5354-104593	CAP, MYL .1μ
577	C606	5354-104593	CAP, MYL .1μ
577	C608	5354-104593	CAP, MYL .1μ
574	C610	5345-477C0962	CAP, MINI ELE 470μ/16V
574	C611	5345-477C0962	CAP, MINI ELE 470μ/16V
574	C612	5345-477C0962	CAP, MINI ELE 470μ/16V
574	C613	5345-477C0962	CAP, MINI ELE 470μ/16V
575	C614	5345-227C0962	CAP, MINI ELE 220μ/16V
575	C615	5345-227C0962	CAP, MINI ELE 220μ/16V
576	C617	5353-030534	CAP, MCA 3P
576	C618	5353-030534	CAP, MCA 3P
576	C619	5353-030534	CAP, MCA 3P
576	C620	5353-030534	CAP, MCA 3P
806	C801	5345-476C0962	CAP, MINI ELE 47μ/16V
808	C803	5353-560534	CAP, MCA 56P
805	C804	5345-336C0962	CAP, MINI ELE 33μ/16V
807	C805	5354-104593	CAP, MYL .1μ
809	C807	5353-150534	CAP, MCA 15P
744	C910	5345-226D0962	CAP, MINI ELE 22μ/25V

**RESISTORS**

515	R15	5134-471J25P	RES, CBN 1/4P 470
515	R16	5134-471J25P	RES, CBN 1/4P 470
514	R17	5134-101J25P	RES, CBN 1/4P 100
514	R18	5134-101J25P	RES, CBN 1/4P 100
513	R19	5134-1R5J25P	RES, CBN 1/4P 1.5
513	R20	5134-1R5J25P	RES, CBN 1/4P 1.5
516	R21	5134-220J25P	RES, CBN 1/4P 22
728	R24	5134-223J25P	RES, CBN 1/4P 22K
730	R52	5134-104J25P	RES, CBN 1/4P 100K
728	R53	5134-223J25P	RES, CBN 1/4P 22K
727	R54	5134-103J25P	RES, CBN 1/4P 10K
724	R55	5134-101J25P	RES, CBN 1/4P 100
733	R59	5232-104J16P	RES, CBN 1/6P 100K
733	R60	5232-104J16P	RES, CBN 1/6P 100K
732	R61	5232-103J16P	RES, CBN 1/6P 10K
731	R65	5134-392J25P	RES, CBN 1/4P 3.9K
725	R66	5134-221J25P	RES, CBN 1/4P 220
659	R101	5134-220J25P	RES, CBN 1/4P 22
662	R102	5134-222J25P	RES, CBN 1/4P 2.2K
676	R103	5232-163J16P	RES, CBN 1/6P 16K
673	R104	5232-822J16P	RES, CBN 1/6P 8.2K
664	R105	5134-223J25P	RES, CBN 1/4P 22K
661	R106	5134-102J25P	RES, CBN 1/4P 1K
660	R107	5134-221J25P	RES, CBN 1/4P 220
677	R108	5232-183J16P	RES, CBN 1/6P 18K
677	R109	5232-183J16P	RES, CBN 1/6P 18K
661	R110	5134-102J25P	RES, CBN 1/4P 1K
674	R111	5232-103J16P	RES, CBN 1/6P 10K
683	R112	5232-104J16P	RES, CBN 1/6P 100K
663	R113	5134-103J25P	RES, CBN 1/4P 10K
664	R114	5134-223J25P	RES, CBN 1/4P 22K
682	R115	5232-683J16P	RES, CBN 1/6P 68K
675	R116	5232-153J16P	RES, CBN 1/6P 15K
672	R117	5232-682J16P	RES, CBN 1/6P 6.8K
667	R118	5232-221J16P	RES, CBN 1/6P 220
681	R119	5232-563J16P	RES, CBN 1/6P 56K
663	R120	5134-103J25P	RES, CBN 1/4P 10K
674	R121	5232-103J16P	RES, CBN 1/6P 10K
679	R122	5232-273J16P	RES, CBN 1/6P 27K
674	R124	5232-103J16P	RES, CBN 1/6P 10K
683	R126	5232-104J16P	RES, CBN 1/6P 100K
683	R127	5232-104J16P	RES, CBN 1/6P 100K

Ser. No.	Ref. No.	Part No.	Description	Ser. No.	Ref. No.	Part No.	Description
674	R128	5232-103J16P	RES, CBN 1/6P 10K	555	R321	5134-101J25P	RES, CBN 1/4P 100
674	R129	5232-103J16P	RES, CBN 1/6P 10K	555	R322	5134-101J25P	RES, CBN 1/4P 100
690	R130	5232-224J16P	RES, CBN 1/6P 220K	555	R323	5134-101J25P	RES, CBN 1/4P 100
683	R131	5232-104J16P	RES, CBN 1/6P 100K	555	R324	5134-101J25P	RES, CBN 1/4P 100
671	R132	5232-562J16P	RES, CBN 1/6P 5.6K	555	R325	5134-101J25P	RES, CBN 1/4P 100
668	R133	5232-102J16P	RES, CBN 1/6P 1K	555	R326	5134-101J25P	RES, CBN 1/4P 100
669	R134	5134-563J25P	RES, CBN 1/4P 56K	555	R327	5134-101J25P	RES, CBN 1/4P 100
675	R135	5232-153J16P	RES, CBN 1/6P 15K	555	R328	5134-101J25P	RES, CBN 1/4P 100
675	R136	5232-153J16P	RES, CBN 1/6P 15K	567	R329	5134-471J25P	RES, CBN 1/4P 470
680	R137	5232-393J16P	RES, CBN 1/6P 39K	567	R330	5134-471J25P	RES, CBN 1/4P 470
678	R138	5232-223J16P	RES, CBN 1/6P 22K	555	R331	5134-101J25P	RES, CBN 1/4P 100
670	R139	5232-332J16P	RES, CBN 1/6P 3.3K	555	R332	5134-101J25P	RES, CBN 1/4P 100
679	R140	5232-273J16P	RES, CBN 1/6P 27K	567	R333	5134-471J25P	RES, CBN 1/4P 470
666	R141	5232-100J16P	RES, CBN 1/6P 10	567	R334	5134-471J25P	RES, CBN 1/4P 470
666	R142	5232-100J16P	RES, CBN 1/6P 10	551	R335	5134-2R2J25P	RES, CBN 1/4P 2.2
666	R143	5232-100J16P	RES, CBN 1/6P 10	551	R336	5134-2R2J25P	RES, CBN 1/4P 2.2
674	R145	5232-103J16P	RES, CBN 1/6P 10K	552	R337	5134-100J25P	RES, CBN 1/4P 10
658	R150	5134-4R7J25P	RES, CBN 1/4P 4.7	552	R338	5134-100J25P	RES, CBN 1/4P 10
658	R151	5134-4R7J25P	RES, CBN 1/4P 4.7	552	R339	5134-100J25P	RES, CBN 1/4P 10
665	R152	5232-4R7J16P	RES, CBN 1/6P 4.7	552	R340	5134-100J25P	RES, CBN 1/4P 10
658	R153	5134-4R7J25P	RES, CBN 1/4P 4.7	556	R341	5134-821J25P	RES, CBN 1/4P 820
686	△ R154	5102-4R75116	RES, FUSE 4.7	556	R342	5134-821J25P	RES, CBN 1/4P 820
687	R156	5232-105J16P	RES, CBN 1/6P 1M	555	R343	5134-101J25P	RES, CBN 1/4P 100
608	R201	5232-333J16P	RES, CBN 1/6P 33K	555	R344	5134-101J25P	RES, CBN 1/4P 100
607	R202	5232-222J16P	RES, CBN 1/6P 2.2K	567	R345	5134-471J25P	RES, CBN 1/4P 470
606	R203	5134-104J25P	RES, CBN 1/4P 100K	567	R346	5134-471J25P	RES, CBN 1/4P 470
605	R204	5134-103J25P	RES, CBN 1/4P 10K	551	R347	5134-2R2J25P	RES, CBN 1/4P 2.2
609	R205	5232-104J16P	RES, CBN 1/6P 100K	551	R348	5134-2R2J25P	RES, CBN 1/4P 2.2
664	R207	5134-223J25P	RES, CBN 1/4P 22K	552	R357	5134-100J25P	RES, CBN 1/4P 10
683	R209	5232-104J16P	RES, CBN 1/6P 100K	552	R358	5134-100J25P	RES, CBN 1/4P 10
683	R210	5232-104J16P	RES, CBN 1/6P 100K	552	R359	5134-100J25P	RES, CBN 1/4P 10
684	R211	5232-334J16P	RES, CBN 1/6P 330K	552	R360	5134-100J25P	RES, CBN 1/4P 10
684	R212	5232-334J16P	RES, CBN 1/6P 330K	555	R361	5134-101J25P	RES, CBN 1/4P 100
666	R213	5232-100J16P	RES, CBN 1/6P 10	555	R362	5134-101J25P	RES, CBN 1/4P 100
683	R214	5232-104J16P	RES, CBN 1/6P 100K	554	R363	5134-470J25P	RES, CBN 1/4P 47
683	R215	5232-104J16P	RES, CBN 1/6P 100K	554	R364	5134-470J25P	RES, CBN 1/4P 47
683	R216	5232-104J16P	RES, CBN 1/6P 100K	726	R369	5134-182J25P	RES, CBN 1/4P 1.8K
683	R217	5232-104J16P	RES, CBN 1/6P 100K	726	R370	5134-182J25P	RES, CBN 1/4P 1.8K
666	R218	5232-100J16P	RES, CBN 1/6P 10	726	R371	5134-182J25P	RES, CBN 1/4P 1.8K
603	R219	5134-102J25P	RES, CBN 1/4P 1K	726	R372	5134-182J25P	RES, CBN 1/4P 1.8K
689	△ R220	5102-4R75116	RES, FUSE 4.7	560	R377	5134-392J25P	RES, CBN 1/4P 3.9K
689	△ R221	5102-4R75116	RES, FUSE 4.7	560	R378	5134-392J25P	RES, CBN 1/4P 3.9K
602	R222	5134-390J25P	RES, CBN 1/4P 39	562	R379	5134-512J25P	RES, CBN 1/4P 5.1K
685	R223	5232-275J16P	RES, CBN 1/6P 2.7M	562	R380	5134-512J25P	RES, CBN 1/4P 5.1K
604	R224	5134-222J25P	RES, CBN 1/4P 2.2K	562	R383	5134-512J25P	RES, CBN 1/4P 5.1K
604	R225	5134-222J25P	RES, CBN 1/4P 2.2K	562	R384	5134-512J25P	RES, CBN 1/4P 5.1K
604	R226	5134-222J25P	RES, CBN 1/4P 2.2K	558	R385	5134-122J25P	RES, CBN 1/4P 1.2K
607	R227	5232-222J16P	RES, CBN 1/6P 2.2K	558	R386	5134-122J25P	RES, CBN 1/4P 1.2K
607	R228	5232-222J16P	RES, CBN 1/6P 2.2K	556	R387	5134-821J25P	RES, CBN 1/4P 820
607	R229	5232-222J16P	RES, CBN 1/6P 2.2K	556	R388	5134-821J25P	RES, CBN 1/4P 820
674	R251	5232-103J16P	RES, CBN 1/6P 10K	561	R389	5134-472J25P	RES, CBN 1/4P 4.7K
674	R252	5232-103J16P	RES, CBN 1/6P 10K	561	R390	5134-472J25P	RES, CBN 1/4P 4.7K
674	R253	5232-103J16P	RES, CBN 1/6P 10K	566	R391	5134-105J25P	RES, CBN 1/4P 1M
674	R254	5232-103J16P	RES, CBN 1/6P 10K	566	R392	5134-105J25P	RES, CBN 1/4P 1M
674	R255	5232-103J16P	RES, CBN 1/6P 10K	564	R393	5134-104J25P	RES, CBN 1/4P 100K
610	R256	5232-105J16P	RES, CBN 1/6 1M	564	R394	5134-104J25P	RES, CBN 1/4P 100K
603	R257	5134-102J25P	RES, CBN 1/4P 1K	565	R395	5134-154J25P	RES, CBN 1/4P 150K
562	R301	5134-512J25P	RES, CBN 1/4P 5.1K	556	R397	5134-821J25P	RES, CBN 1/4P 820
562	R302	5134-512J25P	RES, CBN 1/4P 5.1K	556	R398	5134-821J25P	RES, CBN 1/4P 820
562	R303	5134-512J25P	RES, CBN 1/4P 5.1K	729	R399	5134-154J25P	RES, CBN 1/4P 150K
562	R304	5134-512J25P	RES, CBN 1/4P 5.1K	579	R602	5134-3R3J25P	RES, CBN 1/4P 3.3
563	R305	5134-222J25P	RES, CBN 1/4P 2.2K	579	R603	5134-3R3J25P	RES, CBN 1/4P 3.3
563	R306	5134-222J25P	RES, CBN 1/4P 2.2K	579	R604	5134-3R3J25P	RES, CBN 1/4P 3.3
563	R307	5134-222J25P	RES, CBN 1/4P 2.2K	579	R605	5134-3R3J25P	RES, CBN 1/4P 3.3
563	R308	5134-222J25P	RES, CBN 1/4P 2.2K	585	R606	5232-474J16P	RES, CBN 1/6P 470K
557	R309	5134-102J25P	RES, CBN 1/4P 1K	585	R607	5232-474J16P	RES, CBN 1/6P 470K
557	R310	5134-102J25P	RES, CBN 1/4P 1K	582	R608	5134-224J25P	RES, CBN 1/4P 220K
557	R311	5134-102J25P	RES, CBN 1/4P 1K	584	R609	5232-224J16P	RES, CBN 1/6P 220K
557	R312	5134-102J25P	RES, CBN 1/4P 1K	586	R610	5232-105J16P	RES, CBN 1/6P 1M
557	R313	5134-102J25P	RES, CBN 1/4P 1K	586	R611	5232-105J16P	RES, CBN 1/6P 1M
557	R314	5134-102J25P	RES, CBN 1/4P 1K	585	R612	5232-474J16P	RES, CBN 1/6P 470K
557	R315	5134-102J25P	RES, CBN 1/4P 1K	585	R613	5232-474J16P	RES, CBN 1/6P 470K
557	R316	5134-102J25P	RES, CBN 1/4P 1K	587	R614	5232-184J16P	RES, CBN 1/6P 180K
553	R317	5134-390J25P	RES, CBN 1/4P 39	587	R615	5232-184J16P	RES, CBN 1/6P 180K
553	R318	5134-390J25P	RES, CBN 1/4P 39	586	R616	5232-105J16P	RES, CBN 1/6P 1M
553	R319	5134-390J25P	RES, CBN 1/4P 39	586	R617	5232-105J16P	RES, CBN 1/6P 1M
553	R320	5134-390J25P	RES, CBN 1/4P 39	583	R618	5232-221J16P	RES, CBN 1/6P 220



Ser. No.	Ref. No.	Part No.	Description
583	R619	5232-221J16P	RES, CBN 1/6P 220
583	R620	5232-221J16P	RES, CBN 1/6P 220
583	R621	5232-221J16P	RES, CBN 1/6P 220
578	R622	5232-221J16P	RES, CBN 1/6P 220
583	R623	5232-221J16P	RES, CBN 1/6P 220
583	R624	5232-221J16P	RES, CBN 1/6P 220
581	R625	5134-221J25P	RES, CBN 1/4P 220
580	R626	5134-220J25P	RES, CBN 1/4P 22
580	R627	5134-220J25P	RES, CBN 1/4P 22
588	R631	5134-331J25P	RES, CBN 1/4P 330
588	R632	5134-331J25P	RES, CBN 1/4P 330
588	R633	5134-331J25P	RES, CBN 1/4P 330
588	R634	5134-331J25P	RES, CBN 1/4P 330
583	R635	5232-221J16P	RES, CBN 1/6P 220
583	R636	5232-221J16P	RES, CBN 1/6P 220
814	R801	5232-750J16P	RES, CBN 1/6P 75
810	R805	5134-331J25P	RES, CBN 1/4P 330
811	R807	5134-221J25P	RES, CBN 1/4P 220
813	R809	5232-101J16P	RES, CBN 1/6P 100
812	R810	5134-101J25P	RES, CBN 1/4P 100
748	R910	5232-473J16P	RES, CBN 1/6P 47K
747	R911	5134-470J25P	RES, CBN 1/4P 47
749	R912	5232-271J16P	RES, CBN 1/6P 270
750	R913	5232-392J16P	RES, CBN 1/6P 3.9K

**INTEGRATED CIRCUITS**

622	IC101	5653-CXA1081S	IC, LINEAR
621	IC102	5654-M51594FP	IC, DIGITAL
623	IC103	5653-LA6520	IC, LINEAR
591	IC201	5654-M65820FP	IC, DIGITAL
624	IC203	5653-LA6515	IC, LINEAR
570	IC602	5654-H74H04P	IC, DIGITAL
572	IC603	5654-H74H175P	IC, DIGITAL
571	IC604	5654-H74H164P	IC, DIGITAL
571	IC605	5654-H74H164P	IC, DIGITAL
571	IC606	5654-H74H164P	IC, DIGITAL
571	IC607	5654-H74H164P	IC, DIGITAL
571	IC608	5654-H74H164P	IC, DIGITAL
571	IC609	5654-H74H164P	IC, DIGITAL
573	IC611	5654-PCM61P	IC, DIGITAL
573	IC612	5654-PCM61P	IC, DIGITAL
573	IC613	5654-PCM61P	IC, DIGITAL
573	IC614	5654-PCM61P	IC, DIGITAL
801	IC801	5654-H74H02P	IC, DIGITAL

**TRANSISTORS**

502	△ Q7	5614-2012	XISTOR, NPN A
501	△ Q8	5614-1375	XISTOR, PNP A
504	Q9	5611-1015(GR)	XISTOR, PNP R
503	Q10	5613-1815(GR)	XISTOR, NPN R
504	Q11	5611-1015(GR)	XISTOR, PNP R
503	Q12	5613-1815(GR)	XISTOR, NPN R
505	Q13	5616-2SK246BL	FET, N-CH
505	Q14	5616-2SK246BL	FET, N-CH
711	Q51	5611-1015(GR)	XISTOR, PNP R
711	Q51	5611-1015(GR)	XISTOR, PNP R
711	Q55	5613-RN1202	XISTOR, NPN R
712	Q56	5613-1815(GR)	XISTOR, NPN R
626	Q101	5612-647(C)	XISTOR, PNP A
625	Q102	5613-1815(GR)	XISTOR, NPN R
625	Q103	5613-1815(GR)	XISTOR, NPN R
625	Q104	5613-1815(GR)	XISTOR, NPN R
592	Q201	5613-1815(GR)	XISTOR, NPN R
540	Q301	5611-1015L(GR)	XISTOR, PNP R
540	Q302	5611-1015L(GR)	XISTOR, PNP R
537	Q303	5613-1815L(GR)	XISTOR, NPN R
537	Q304	5613-1815L(GR)	XISTOR, NPN R
537	Q305	5613-1815L(GR)	XISTOR, NPN R
537	Q306	5613-1815L(GR)	XISTOR, NPN R
540	Q307	5611-1015L(GR)	XISTOR, PNP R
540	Q308	5611-1015L(GR)	XISTOR, PNP R
537	Q309	5613-1815L(GR)	XISTOR, NPN R
537	Q310	5613-1815L(GR)	XISTOR, NPN R
540	Q311	5611-1015L(GR)	XISTOR, PNP R
540	Q312	5611-1015L(GR)	XISTOR, PNP R
539	Q313	5611-950L(Y)	XISTOR, PNP R
539	Q314	5611-950L(Y)	XISTOR, PNP R
537	Q315	5613-1815L(GR)	XISTOR, NPN R

Ser. No.	Ref. No.	Part No.	Description
537	Q316	5613-1815L(GR)	XISTOR, NPN R
539	Q317	5611-950(Y)	XISTOR, PNP R
539	Q318	5611-950(Y)	XISTOR, PNP R
537	Q319	5613-1815L(GR)	XISTOR, NPN R
537	Q320	5613-1815L(GR)	XISTOR, NPN R
541	Q325	5616-SK246GR2	FET, N-CH
541	Q326	5616-SK246GR2	FET, N-CH
541	Q327	5616-SK246GR2	FET, N-CH
541	Q328	5616-SK246GR2	FET, N-CH
713	Q331	5613-2878(B)	XISTOR, NPN R
713	Q332	5613-2878(B)	XISTOR, NPN R
713	Q333	5613-2878(B)	XISTOR, NPN R
713	Q334	5613-2878(B)	XISTOR, NPN R
543	Q336	5611-RN2202	XISTOR, PNP R
538	Q337	5613-2878(B)	XISTOR, NPN R
538	Q338	5613-2878(B)	XISTOR, NPN R
741	Q911	5611-RN2201	XISTOR, PNP R

**DIODES**

506	D15	5635-HZ7A1L	DIODE, ZENER
506	D16	5635-HZ7A1L	DIODE, ZENER
715	D17	5631-1S2473	DIODE, DET
715	D53	5631-1S2473	DIODE, DET
717	D54	5635-HZ6A2L	DIODE, ZENER
716	D55	5631-1SS133	DIODE, DET
627	D103	5631-1SS133	DIODE, DET
628	D106	5631-1SS133	DIODE, DET
542	D301	5631-1S2473	DIODE, DET
542	D302	5631-1S2473	DIODE, DET

**COIL**

803	T801	5933-SO801	COIL CASE, 10
-----	------	------------	---------------

**CONTROLS**

657	VR101	5101-2230194	RES, SEMI FIX 22K, EF BALANCE
656	VR102	5101-5020194	RES, SEMI FIX 5K, FOCUS OFFSET
589	VR601	5101-10401934	RES, SEMI FIX 100K, LOW LEVEL LINEARITY
589	VR602	5101-10401934	RES, SEMI FIX 100K, LOW LEVEL LINEARITY
589	VR603	5101-10401934	RES, SEMI FIX 100K, LOW LEVEL LINEARITY
589	VR604	5101-10401934	RES, SEMI FIX 100K, LOW LEVEL LINEARITY

**MISCELLANEOUS**

775	△ CN2	4443-090185	CONNECTOR
772	CN113	4443-0501140	CONNECTOR
771	CN114	4443-0801140	CONNECTOR
771	CN115	4443-0801140	CONNECTOR
773	CN117	4443-0401140	CONNECTOR
776	CN201	4443-05501030	CONNECTOR
762	△ J301	4489-02501002	2 PIN JACK, FIXED OUTPUT
765	△ J801	4481-00501	1 PIN JACK, COAXIAL DIGITAL OUTPUT
764	J910	4451-00184	JACK, REMOTE INPUT
764	J911	4451-00184	JACK, REMOTE INPUT
614	L201	5995-1R5J107	COIL W/ CORE
742	PH910	5624-ON3131	PHOTO COUPLR
613	RC250	5212-SC305103	R COMPOSITE
788	TP1	4214-132	TERMINAL
688	TP101	4214-132	TERMINAL
688	TP102	4214-132	TERMINAL
688	TP103	4214-132	TERMINAL
688	TP104	4214-132	TERMINAL
611	TP201	4214-132	TERMINAL
611	TP202	4214-132	TERMINAL
611	TP203	4214-132	TERMINAL
611	TP204	4214-132	TERMINAL
568	TP301	4214-132	TERMINAL
816	TP801	4214-132	TERMINAL
593	X201	5691-S1702852	XTAL, OSC, 8.4672 MHZ
786	W101	4242-RO107111	JUNPER LEAD

Ser. No.	Ref. No.	Part No.	Description
<b>PCB-2 FRONT P.C. BOARD</b>			
<b>CAPACITORS</b>			
693	C401	5345-478B0951	CAP, MINI ELE 47μ/10V
694	C402	5354-104593	CAP, MYL .1μ
694	C403	5354-104593	CAP, MYL .1μ
706	C404	5345-478B0951	CAP, MINI ELE 47μ/10V

<b>RESISTORS</b>			
696	R401	5134-4R7J25P	RES, CBN 1/4P 4.7
708	R402	5134-102J25P	RES, CBN 1/4P 1K
697	R403	5134-100J25P	RES, CBN 1/4P 10
709	R404	5134-103J25P	RES, CBN 1/4P 10K
709	R405	5134-103J25P	RES, CBN 1/4P 10K
709	R406	5134-103J25P	RES, CBN 1/4P 10K
709	R407	5134-103J25P	RES, CBN 1/4P 10K
707	R408	5134-101J25P	RES, CBN 1/4P 100
710	R409	5134-221J25P	RES, CBN 1/4P 220

<b>INTEGRATED CIRCUIT</b>			
691	IC401	5654-M957-243	IC, DIGITAL

<b>DIODES</b>			
703	D401	5631-1S2473	DIODE, DET
703	D402	5631-1S2473	DIODE, DET
703	D403	5631-1S2473	DIODE, DET
703	D404	5631-1S2473	DIODE, DET
703	D405	5631-1S2473	DIODE, DET
703	D406	5631-1S2473	DIODE, DET
704	D407	5631-1S2473	DIODE, DET
704	D408	5631-1S2473	DIODE, DET

<b>MISCELLANEOUS</b>			
777	CB401	4443-05401030	CONNECTOR
699	FL401	5722-046	TUBE DISPLAY
700	RCV401	6143-00802	RECEIVER BLOCK, REMOTE SENSOR
702	SW405	4437-01202	SWITCH, PU-TC, TIME
702	SW406	4437-01202	SWITCH, PU-TC, DISPLAY
701	SW418	4437-01201	SWITCH, PU-TC, REPEAT
702	SW423	4437-01202	SWITCH, PU-TC, PROGRAM
701	SW425	4437-01201	SWITCH, PU-TC, OPEN/CLOSE
701	SW426	4437-01201	SWITCH, PU-TC, STOP
701	SW427	4437-01201	SWITCH, PU-TC, PLAY
701	SW428	4437-01201	SWITCH, PU-TC, PAUSE
701	SW429	4437-01201	SWITCH, PU-TC, SKIP FORWARD
701	SW430	4437-01201	SWITCH, PU-TC, SKIP BACK
701	SW431	4437-01201	SWITCH, PU-TC, SEARCH FORWARD
701	SW432	4437-01201	SWITCH, PU-TC, SEARCH BACK
783	W401	4163-0120020	CONNECTOR W/W

**PCB-4 MOTOR P. C. BOARD**

<b>CAPACITORS</b>			
759	△ C1	5352-S010M103	CAP, MIL .01μ <b>Ⓡ</b>
759B	△ C1	5352-1030958	CAP, MIL .01μ <b>Ⓡ Ⓢ</b>
529	C4	5354-104593	CAP, MIL .01μ
529	C5	5354-104593	CAP, MIL .01μ
529	C6	5354-104593	CAP, MIL .01μ
527	C7	5345-226FO962	CAP, MINI ELE 22μ/50V
526	C7	5345-477E0962	CAP, MINI ELE 470μ/35V
524	C16	5345-478C0962	CAP, MINI ELE 4700μ/16V
524	C17	5345-478C0962	CAP, MINI ELE 4700μ/16V
531	C30	5359-S010J471	CAP, PPP 470P
523	C32	5345-107B0962	CAP, MINI ELE 100μ/10V
528	C51	5345-226D0962	CAP, MINI ELE 22μ/25V
525	C57	5345-108D0962	CAP, MINI ELE 1000μ/25V

<b>RESISTORS</b>			
002B	△ R1	5135-335J50P	RES, CBN 1/2P 3.3M <b>Ⓡ Ⓢ</b>
534	R29	5134-223J25P	RES, CBN 1/4P 22K
533	R51	5134-182J25P	RES, CBN 1/4P 1.8K
532	R56	5135-331522	RES, CBN 1/2P 330

Ser. No.	Ref. No.	Part No.	Description
<b>DIODES</b>			
522	△ D5	5632-S5566B	DIODE, RECT
522	△ D6	5632-S5566B	DIODE, RECT
522	△ D7	5632-S5566B	DIODE, RECT
522	△ D8	5632-S5566B	DIODE, RECT
521	△ D9	5632-S5566B	DIODE, RECT
521	△ D10	5632-S5566B	DIODE, RECT
518	D11	5635-HZ5B2	DIODE, ZENER
519	D12	5635-HZ27-2	DIODE, ZENER
522	△ D19	5632-S5566B	DIODE, RECT
522	△ D20	5632-S5566B	DIODE, RECT
522	△ D51	5632-S5566B	DIODE, RECT
522	△ D52	5632-S5566B	DIODE, RECT
521	△ D56	5632-S5566B	DIODE, RECT
520	D57	5635-HZ7B2L	DIODE, ZENER

<b>TRANSFORMERS</b>			
755	△ T1	5584-T1601	XFORMER, POWER <b>Ⓡ</b>
755	△ T1	5584-T1602	XFORMER, POWER <b>Ⓡ Ⓢ</b>

<b>MISCELLANEOUS</b>			
785	JL2	4242-RO505121	JUMPER LEAD
792	JL3	4242-RO504121	JUMPER LEAD
761	△ SW1	4433-01301	SWITCH, PU-PW, POWER
789	△ TM1	4214-122	TERMINAL
789	△ TM2	4214-122	TERMINAL
784		2240-Z092	HOLDER, JL2

<b>CHASSIS MISCELLANEOUS</b>			
787	JL401	4242-S0330181	JUMPER LEAD
781	LCN113	4163-03212005	CONNECTOR W/W
779	LCN114	4163-03211008	CONNECTOR W/W
780	LCN115	4163-03211008	CONNECTOR W/W
782	LCN117	4163-03207004	CONNECTOR W/W
757	△ P1	4161-03601202	AC CORD W/PLUG <b>Ⓡ</b>
757	△ P1	4161-03701220	AC CORD W/PLUG <b>Ⓡ Ⓢ</b>
758		4161-71184	CORD W/PLUG, RCA CORD

<b>PACKAGE PARTS LIST</b>			
023		1756-03108	LABEL, (1) LABEL (X2) <b>Ⓡ Ⓢ</b>
026		1111-M30253	OWNER GUIDE, SAFETY GUIDE <b>Ⓡ Ⓢ</b>
			<b>Ⓡ Ⓢ</b>
	105	1111-0730M152	OWNER GUIDE, IB <b>Ⓡ</b>
	105	1111-0730M152	OWNER GUIDE, IB <b>Ⓡ Ⓢ</b>
	106	1119-01203	ATTACH SHEET, UL SAFETY <b>Ⓡ</b>
	107	1113-2501	OWNER CARD, REPLY CARD <b>Ⓡ</b>
	108	1119-04502	ATTACH SHEET, SERVICE SHOP GUIDE <b>Ⓡ</b>
	109	1116-03802	GUARANT CARD <b>Ⓡ</b>
	114	1221-28133	CARTON BOX <b>Ⓡ Ⓢ</b>
	114	1221-28132	CARTON BOX <b>Ⓡ</b>
	115	1222-7366	CUSHION, R
	116	1222-7367	CUSHION, L
	117	1223-R0420055	SOFT SHEET, FRONT PANEL
	118	1223-00207018	SOFT SHEET, LID
	119	1241-R0160601	POLYETHY BAG, SET
	120	1241-R0123351	POLYETHY BAG, IB
	147	1756-11604	LABEL, DHHS CARD <b>Ⓡ</b>
	148	1756-11701	LABEL DHHS CARD <b>Ⓡ</b>
	790	4191-0355	BATTERY, DRY
	791	6142-07404	REMOTE CONTROL UNIT

IC101 : CXA1081S  
RF Amp.

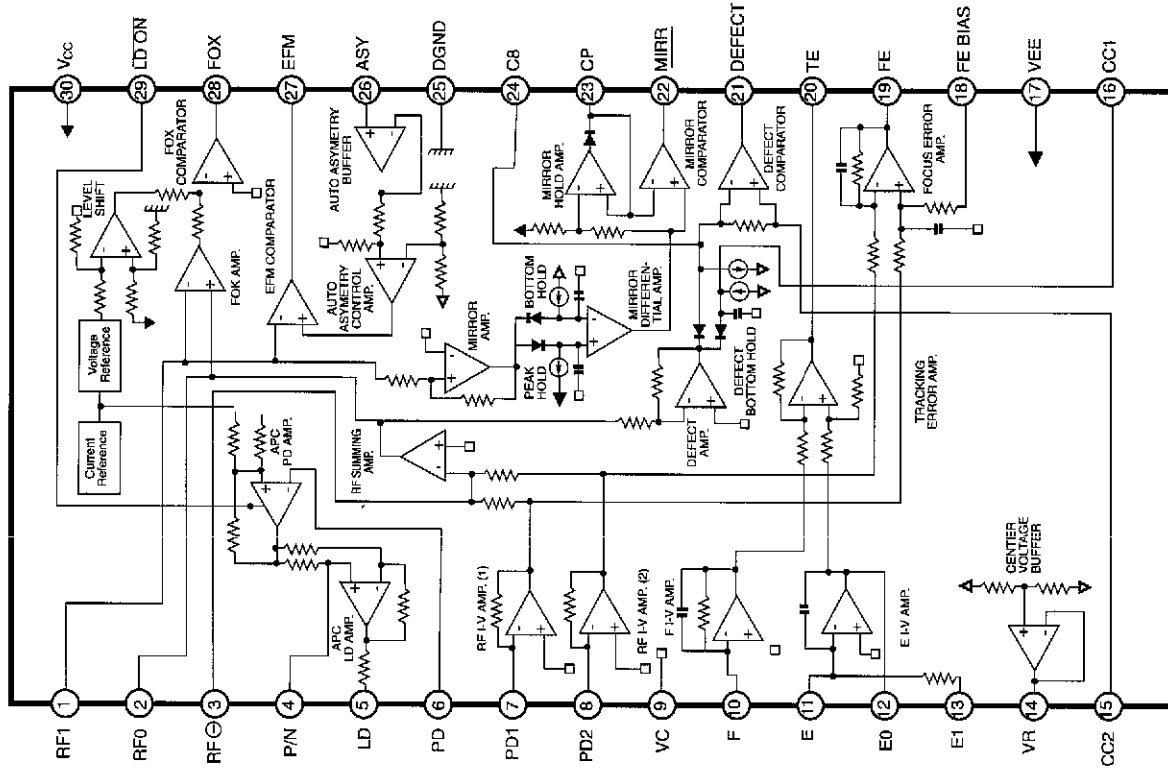

IC102 : M51594FP  
Optical Pick-up Servo Control

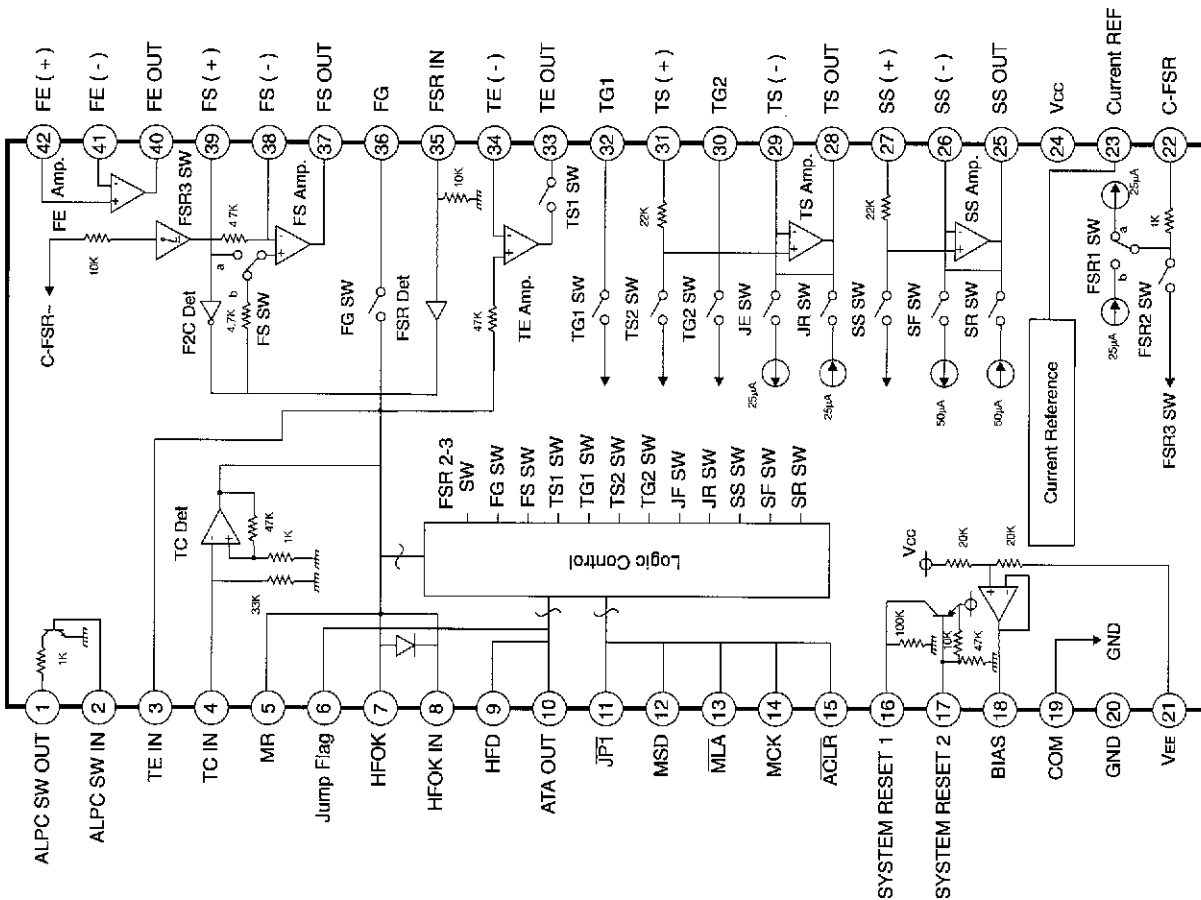

# IC201 : M65820FP Digital Signal Processor

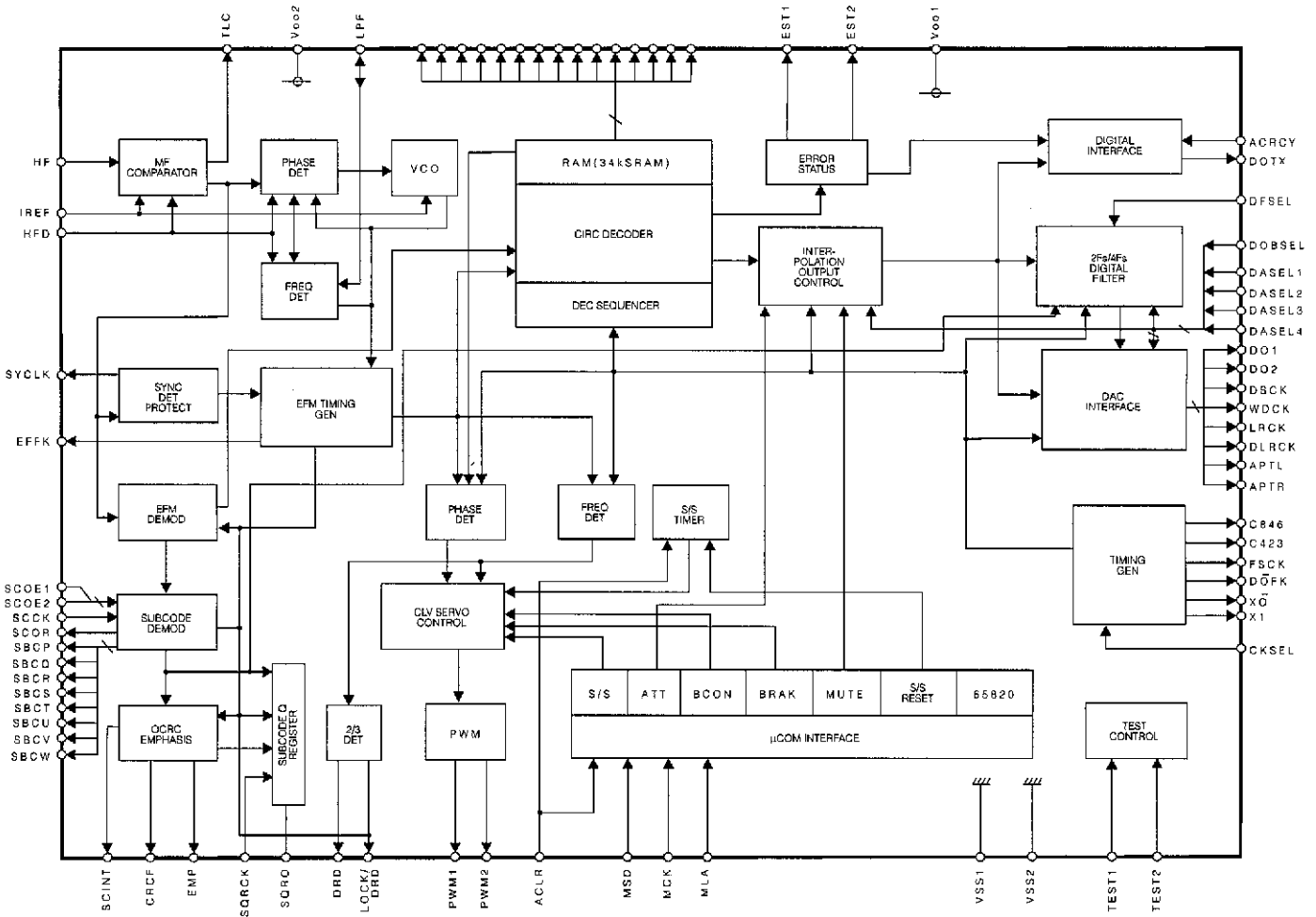

## IC201

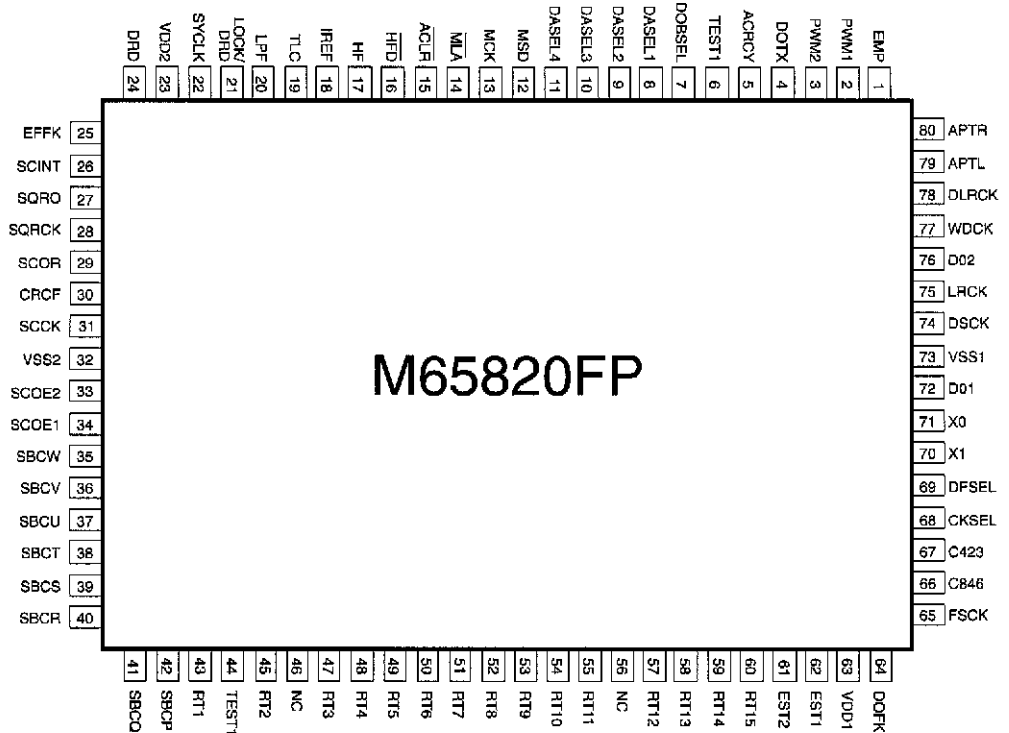

**IC401 : M957-243**  
**Microcomputer**

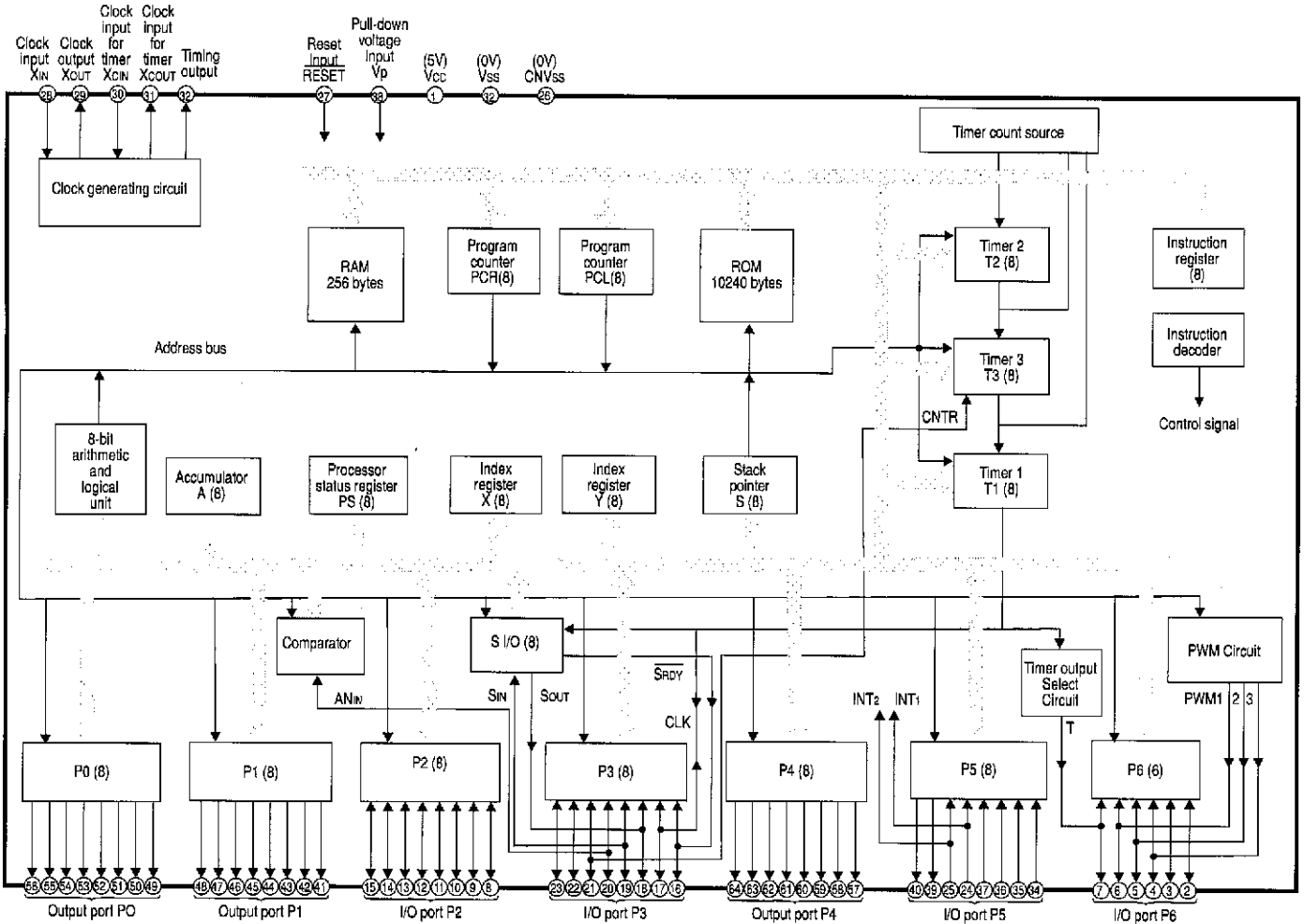

**IC602 : H74H04P**  
**Hex Inverter**

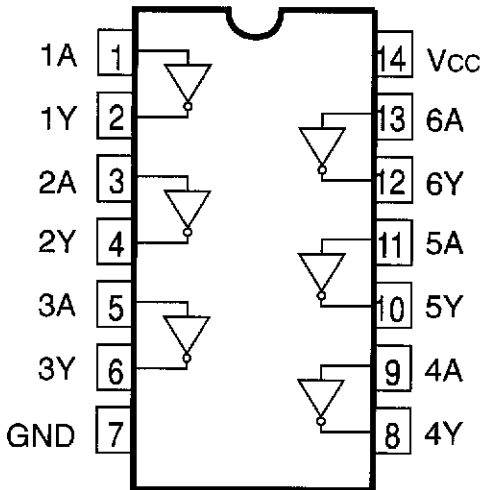

**IC603 : H74H164P**  
**8-bit Shift Register**

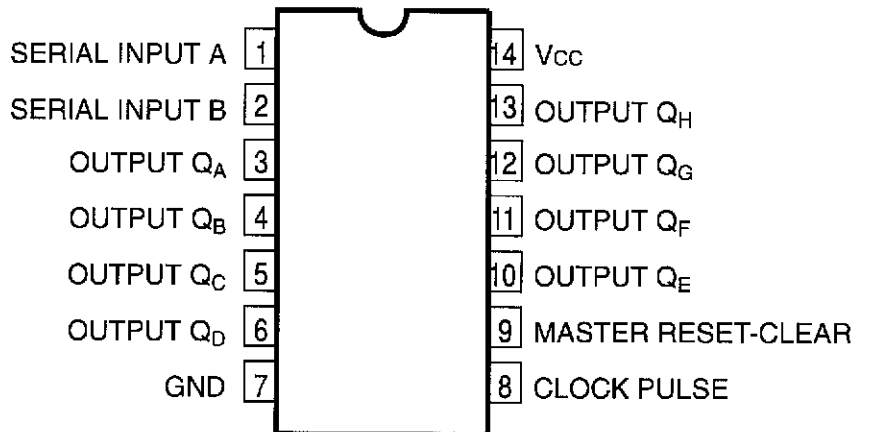

**IC603**

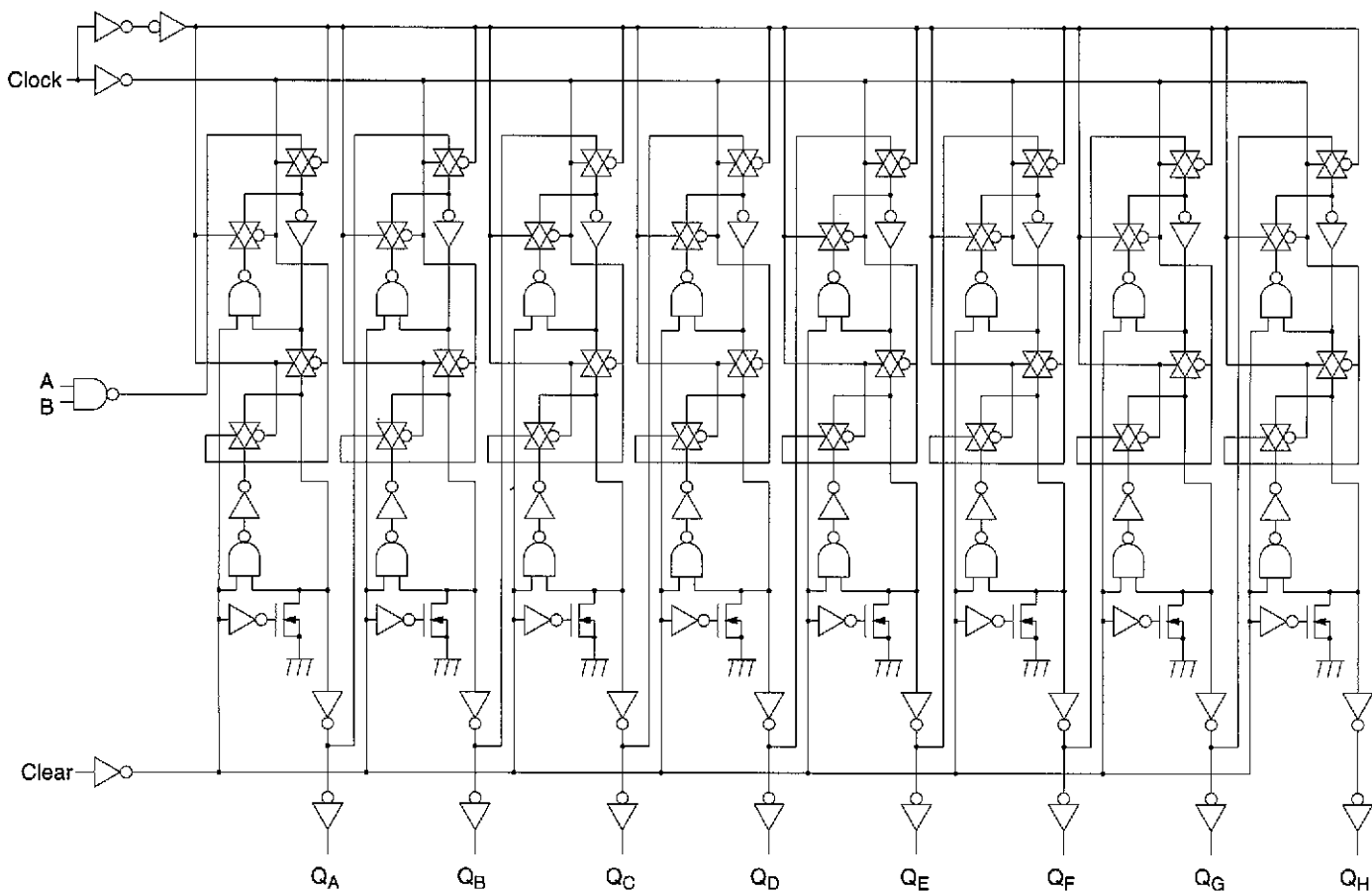

**IC611 -614 : PCM61P  
D/A Converter**

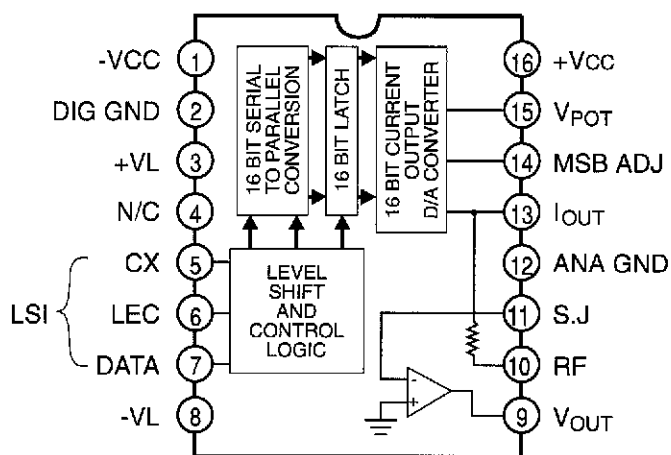

**IC801 : T74HC02P  
Buffer Amp.**

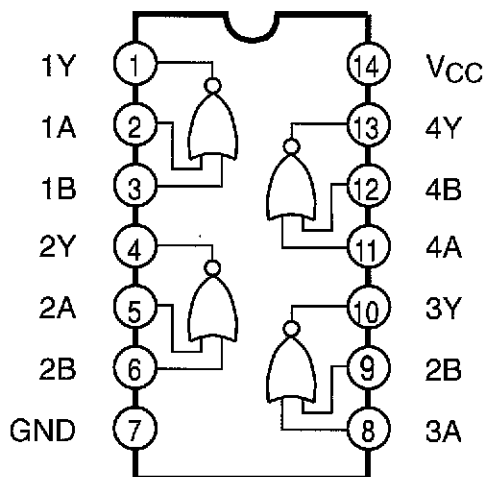

PCB-1 MAIN

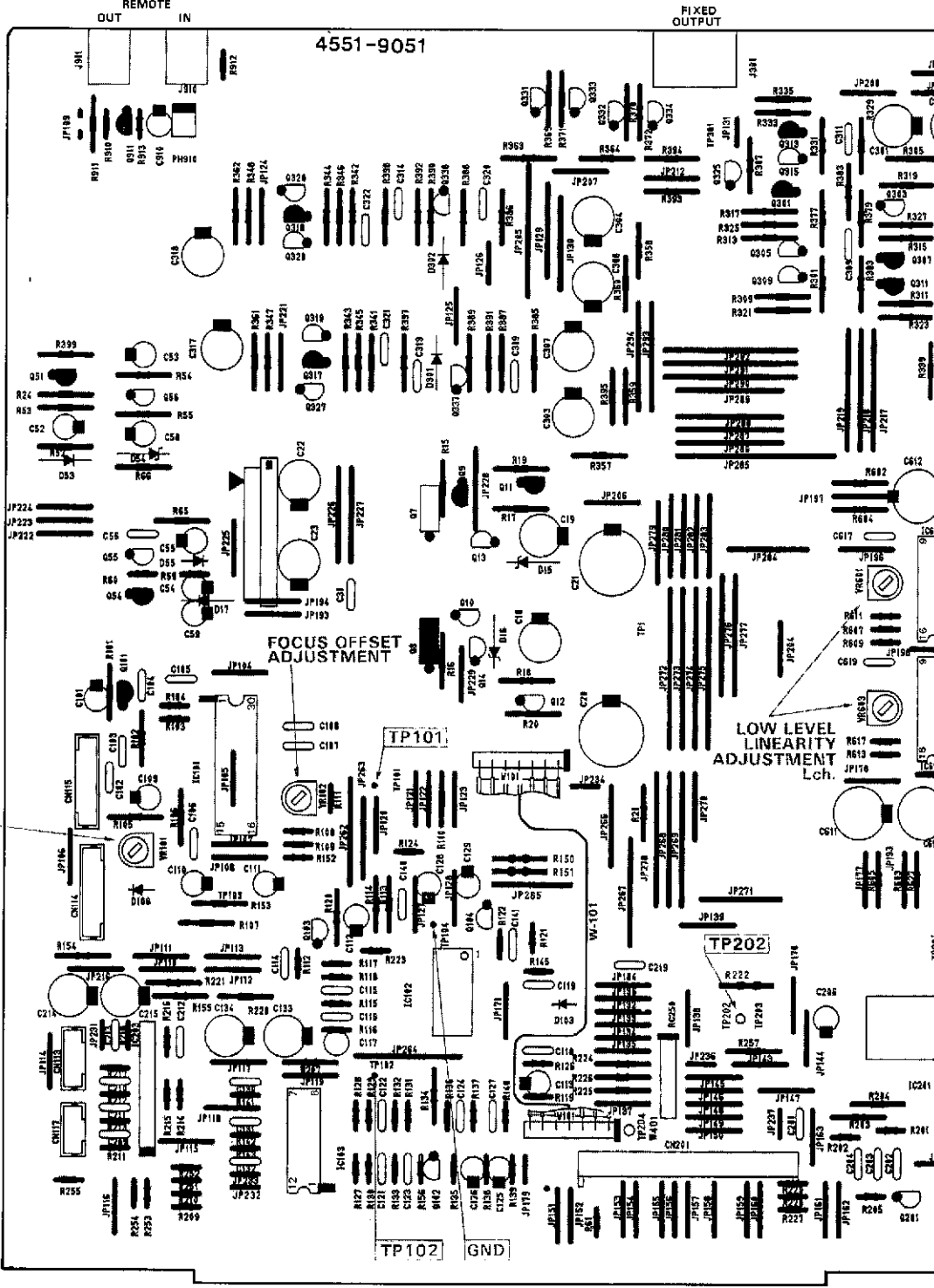

REMOTE  
OUT IN

FIXED  
OUTPUT

4551-9051

EF BALANCE  
ADJUSTMENT

FOCUS OFFSET  
ADJUSTMENT

LOW LEVEL  
LINEARITY  
ADJUSTMENT  
Lch.

TP102 GND

TP202

TP101

TP201

DIGITAL OUTPUT  
COAXIAL SHIELD PLATE

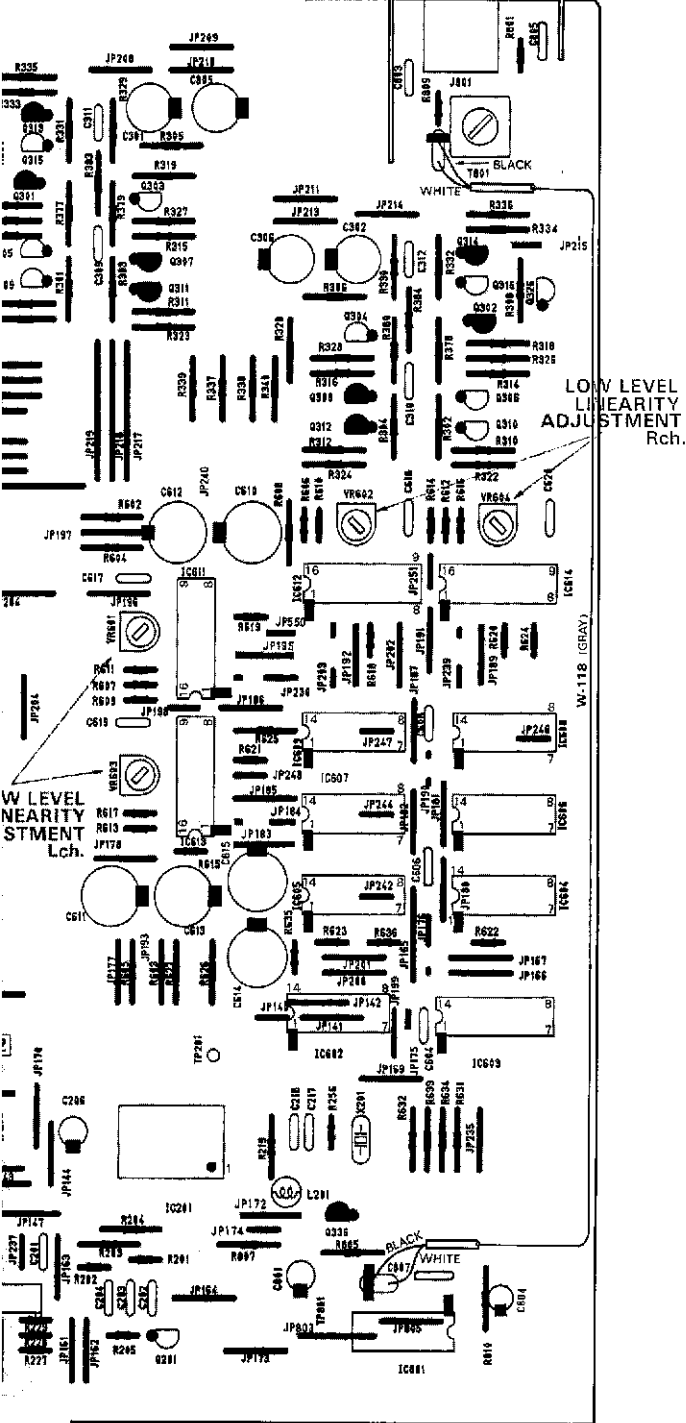

PCB-2 FRONT

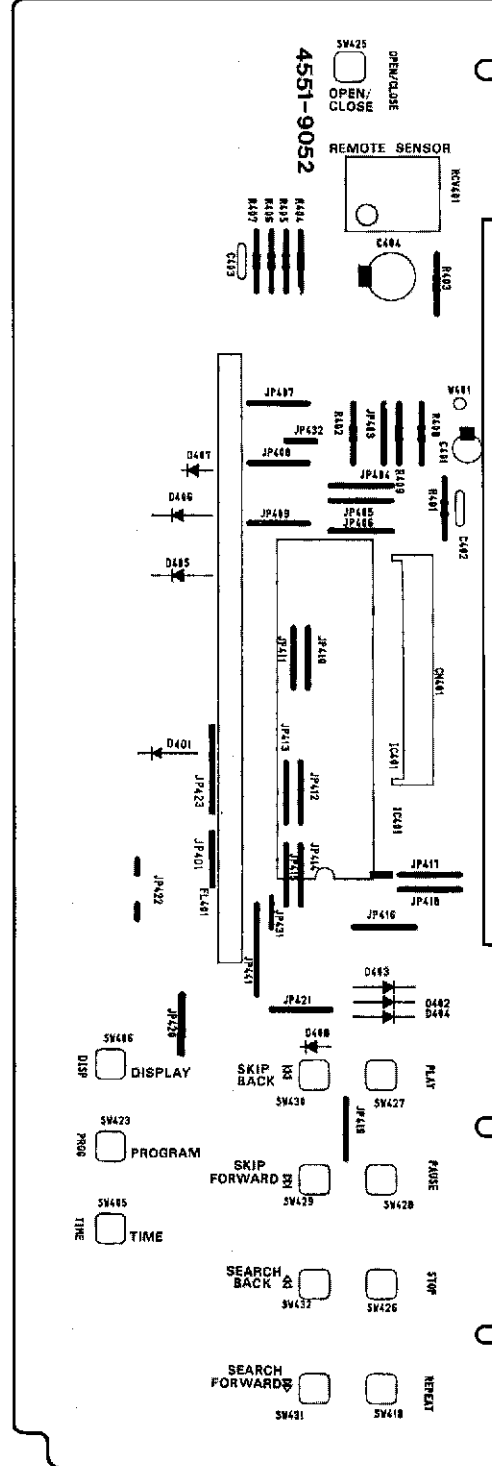



P. C. BOARDS (2)

PCB-4 POWER SUPPLY

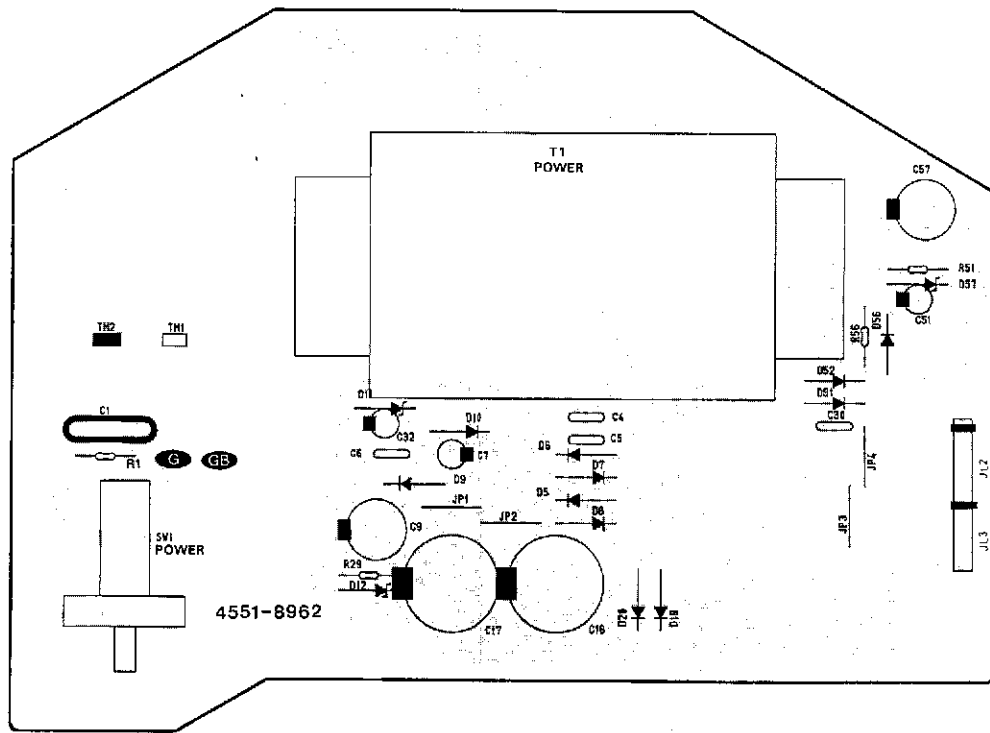

SCHEMATIC DIAGRAM (1)

SCHEMATIC DIAGRAM (3)

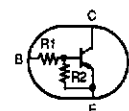
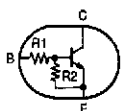
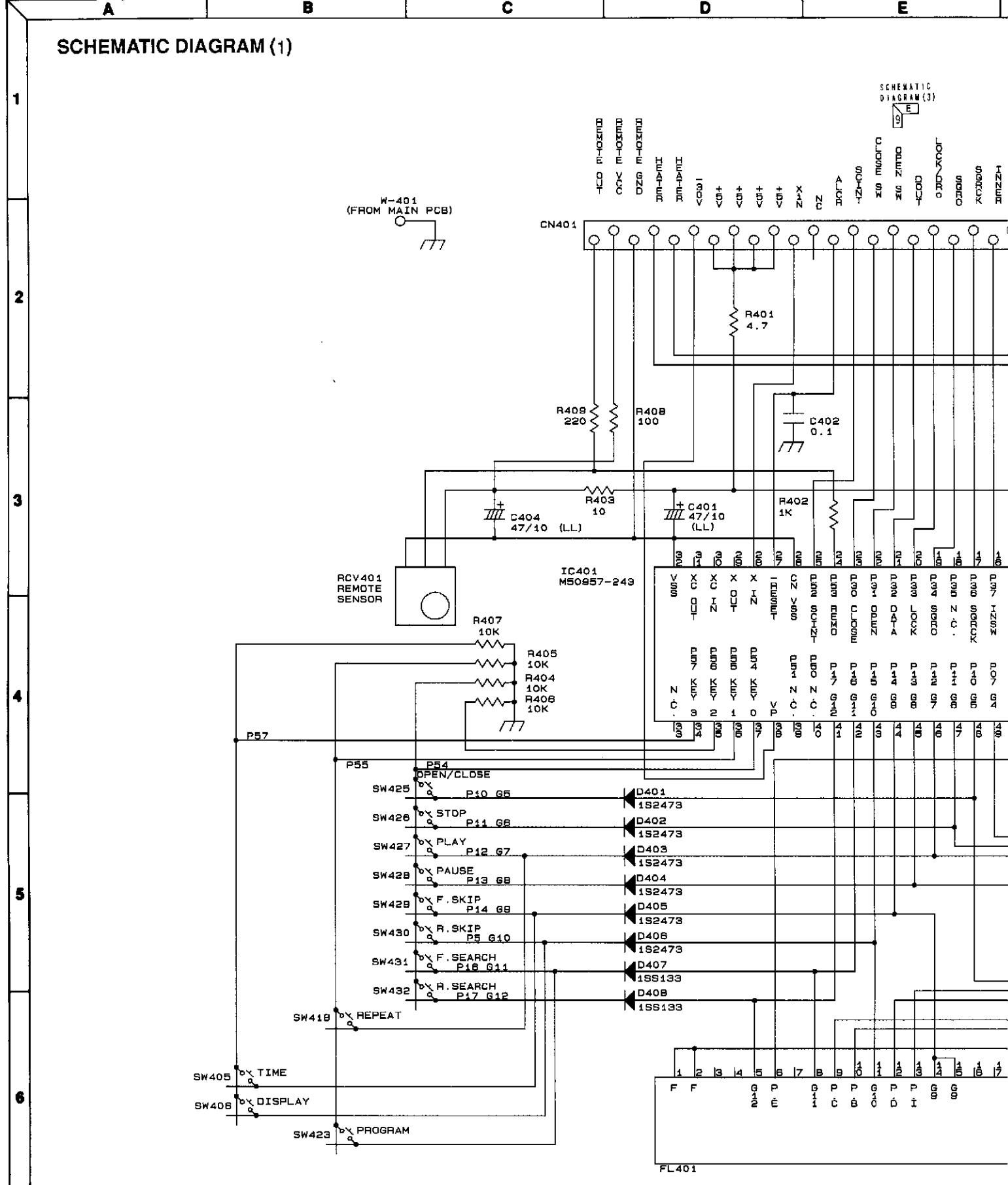

Type	R1(kΩ)	R2(kΩ)
RN1202	10	10

Type	R1(kΩ)	R2(kΩ)
RN2201	10	10

- NOTE :
1. ALL RESISTAN K=1000 (ohm)
  2. THE WATTAGE
  3. ALL CAPACITA P=UF
  4. SAFETY REQUI THESE COMPON



SCHEMATIC  
DIAGRAM (3)

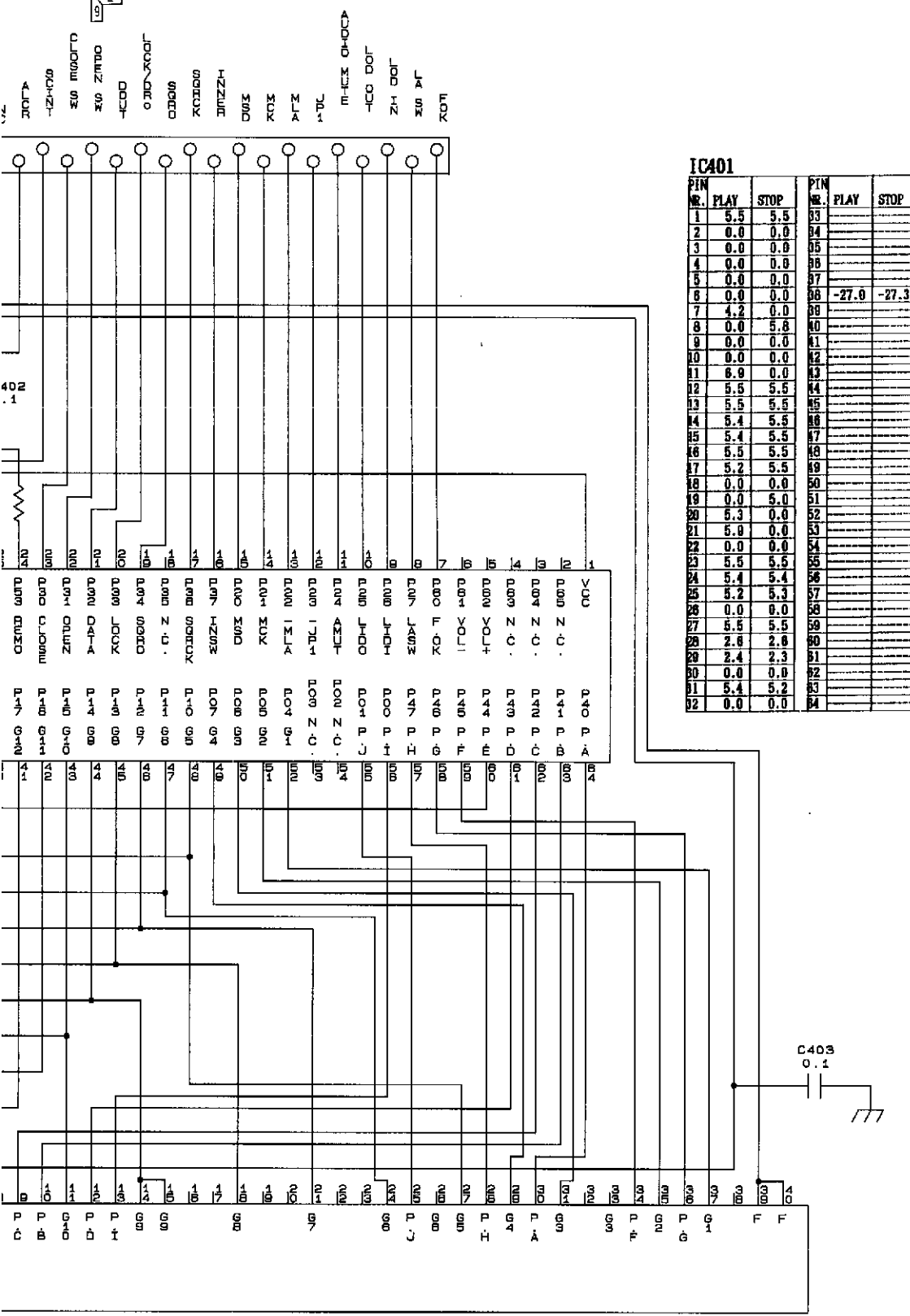

IC401

PIN NR.	PLAY	STOP	PIN NR.	PLAY	STOP
1	5.5	5.5	33		
2	0.0	0.0	34		
3	0.0	0.0	35		
4	0.0	0.8	36		
5	0.0	0.0	37		
6	0.0	0.0	38	-27.0	-27.3
7	4.2	0.0	39		
8	0.0	0.0	40		
9	0.0	0.0	41		
10	0.0	0.0	42		
11	8.9	0.0	43		
12	5.5	5.5	44		
13	5.5	5.5	45		
14	5.4	5.5	46		
15	5.4	5.5	47		
16	5.5	5.5	48		
17	5.2	5.5	49		
18	0.0	0.0	50		
19	0.0	5.0	51		
20	5.3	0.0	52		
21	5.9	0.0	53		
22	0.0	0.0	54		
23	5.5	5.5	55		
24	5.4	5.4	56		
25	5.2	5.3	57		
26	0.0	0.0	58		
27	5.5	5.5	59		
28	2.8	2.8	60		
29	2.4	2.3	61		
30	0.0	0.0	62		
31	5.4	5.2	63		
32	0.0	0.0	64		

NOTE :

1. ALL RESISTANCES VALUES ARE IN [ohm].  
K=1000 [ohm], M=1000K [ohm]
2. THE WATTAGE OF RESISTANCES IS 1/4W UNLESS OTHERWISE NOTED.
3. ALL CAPACITANCES VALUES ARE IN UF UNLESS OTHERWISE NOTED.  
P=10UF
4. SAFETY REQUIREMENTS COMPONENTS IN ACCORDANCE WITH PRESENT SAFETY REGULATIONS.
5. THESE COMPONENTS MUST ONLY BE REPLACED BY ORIGINAL PARTS.



SCHEMATIC DIAGRAM (2)

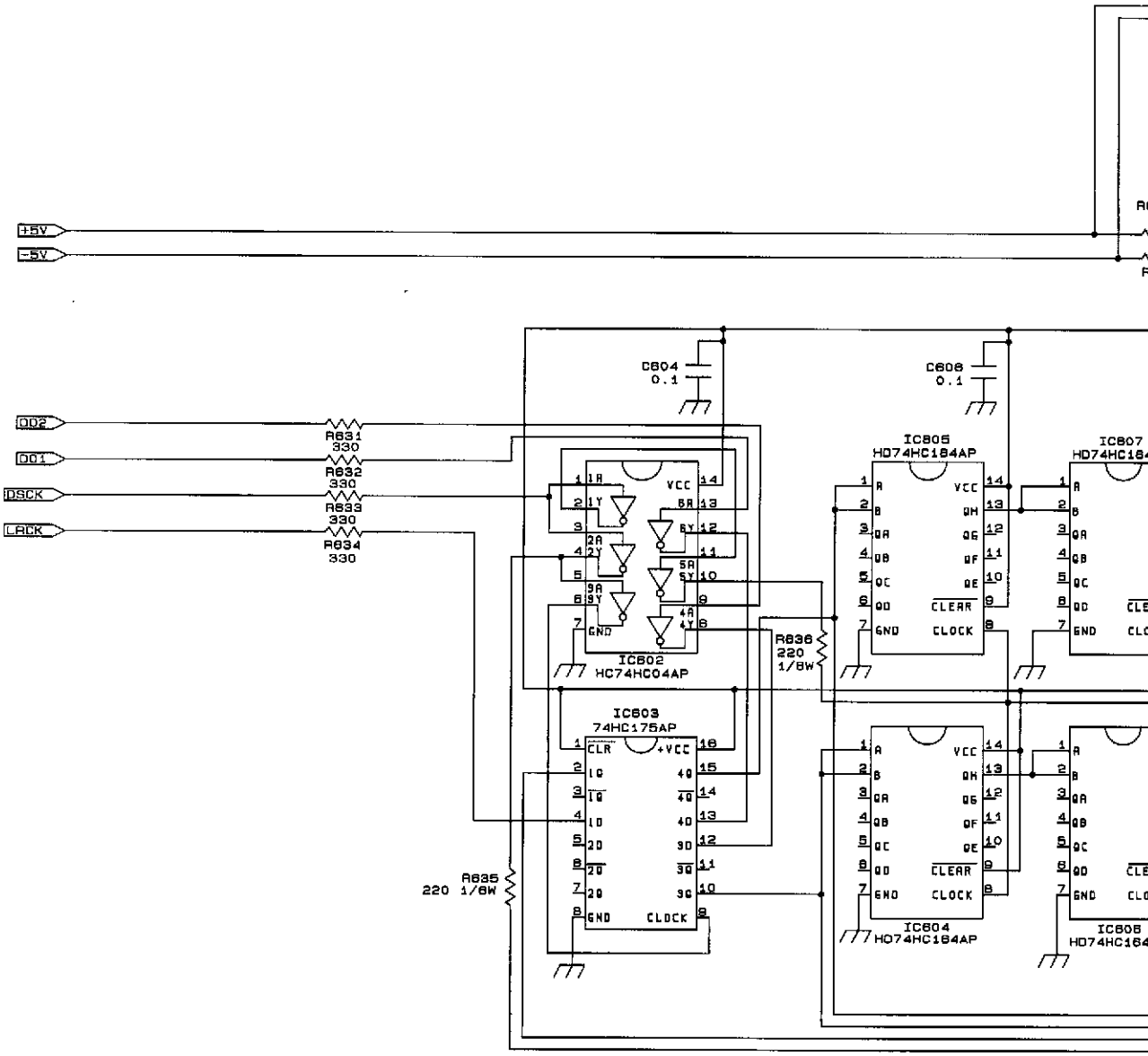

IC602			IC603			IC604			IC605			IC606			IC607		
PIN NR.	PLAY	STOP	PIN NR.	PLAY	STOP	PIN NR.	PLAY	STOP	PIN NR.	PLAY	STOP	PIN NR.	PLAY	STOP	PIN NR.	PLAY	STOP
1	2.8	2.8	1	5.5	5.8	1	2.7	5.5	1	2.7	5.5	1	2.7	5.5	1	2.7	5.5
2	2.7	2.7	2	2.7	2.8	2	2.7	5.5	2	2.7	5.5	2	2.7	5.5	2	2.7	5.5
3	2.8	2.8	3	2.7	2.8	3	2.7	5.5	3	2.7	5.5	3	2.7	5.5	3	2.7	5.5
4	2.7	2.7	4	2.8	2.8	4	2.7	5.5	4	2.7	5.5	4	2.7	5.5	4	2.7	5.5
5	2.7	2.7	5	0.0	0.0	5	2.7	5.5	5	2.7	5.5	5	2.7	5.5	5	2.7	5.5
6	2.7	2.7	6	5.5	5.8	6	2.7	5.5	6	2.7	5.5	6	2.7	5.5	6	2.7	5.5
7	0.0	0.0	7	0.0	0.0	7	0.0	0.0	7	0.0	0.0	7	0.0	0.0	7	0.0	0.0
8	2.7	5.5	8	0.0	0.0	8	2.7	2.7	8	2.7	2.7	8	2.7	2.7	8	2.7	2.7
9	2.8	0.0	9	2.7	2.7	9	5.4	5.5	9	5.5	5.5	9	5.5	5.5	9	5.5	5.5
10	2.7	2.7	10	2.7	5.5	10	2.7	5.5	10	2.7	5.5	10	2.7	5.5	10	2.7	5.5
11	2.7	2.7	11	2.7	0.0	11	2.7	5.5	11	2.7	5.5	11	2.7	5.5	11	2.7	5.5
12	2.7	5.5	12	2.7	5.5	12	2.7	5.5	12	2.7	5.5	12	2.7	5.5	12	2.7	5.5
13	2.6	0.0	13	2.7	5.5	13	2.7	5.5	13	2.7	5.5	13	2.7	5.5	13	2.7	5.5
14	5.5	5.5	14	2.7	0.0	14	5.4	5.5	14	5.5	5.5	14	5.5	5.5	14	5.5	5.5
			15	2.7	5.5												
			16	5.4	5.5												

NOTE :  
 1. ALL  
 2. THE  
 3. ALL  
 4. SAFE  
 5. THESE

1

2

3

4

5

6

7

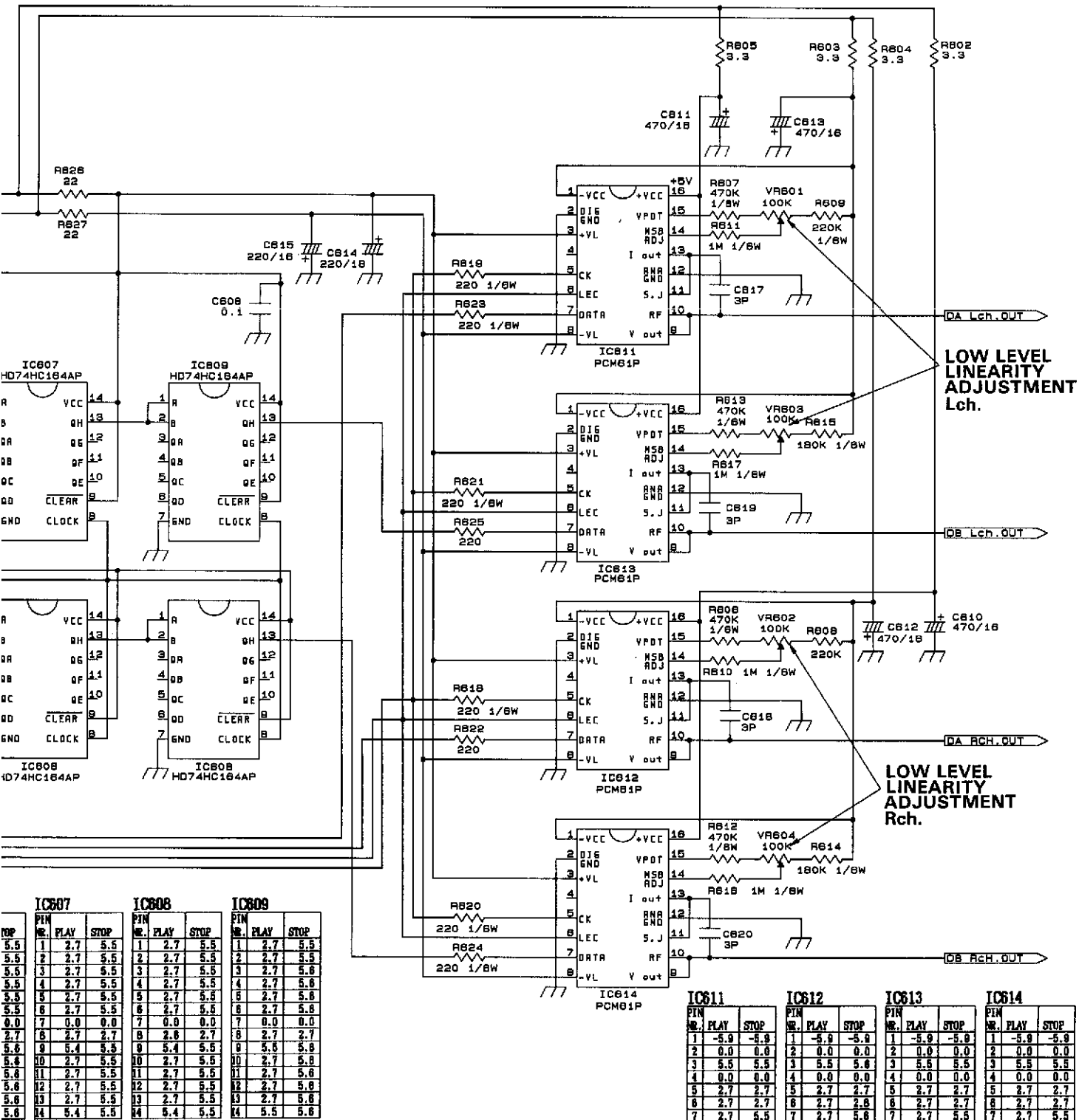

LOW LEVEL LINEARITY ADJUSTMENT Lch.

LOW LEVEL LINEARITY ADJUSTMENT Rch.

IC607			IC608			IC609			
TOP	PIN		PIN	PLAY	STOP	PIN	PLAY	STOP	
5.5	1	2.7	5.5	1	2.7	5.5	1	2.7	5.5
5.5	2	2.7	5.5	2	2.7	5.5	2	2.7	5.5
5.5	3	2.7	5.5	3	2.7	5.5	3	2.7	5.5
5.5	4	2.7	5.5	4	2.7	5.5	4	2.7	5.5
5.5	5	2.7	5.5	5	2.7	5.5	5	2.7	5.5
5.5	6	2.7	5.5	6	2.7	5.5	6	2.7	5.5
0.0	7	0.0	0.0	7	0.0	0.0	7	0.0	0.0
2.7	8	2.7	2.7	8	2.7	2.7	8	2.7	2.7
5.5	9	5.4	5.5	9	5.4	5.5	9	5.5	5.5
5.5	10	2.7	5.5	10	2.7	5.5	10	2.7	5.5
5.5	11	2.7	5.5	11	2.7	5.5	11	2.7	5.5
5.5	12	2.7	5.5	12	2.7	5.5	12	2.7	5.5
5.5	13	2.7	5.5	13	2.7	5.5	13	2.7	5.5
5.5	14	5.4	5.5	14	5.4	5.5	14	5.5	5.5

IC611			IC612			IC613			IC614		
PIN	PLAY	STOP	PIN	PLAY	STOP	PIN	PLAY	STOP	PIN	PLAY	STOP
1	-5.0	-5.0	1	-5.0	-5.0	1	-5.0	-5.0	1	-5.0	-5.0
2	0.0	0.0	2	0.0	0.0	2	0.0	0.0	2	0.0	0.0
3	5.5	5.5	3	5.5	5.5	3	5.5	5.5	3	5.5	5.5
4	0.0	0.0	4	0.0	0.0	4	0.0	0.0	4	0.0	0.0
5	2.7	2.7	5	2.7	2.7	5	2.7	2.7	5	2.7	2.7
6	2.7	2.7	6	2.7	2.7	6	2.7	2.7	6	2.7	2.7
7	2.7	5.5	7	2.7	5.5	7	2.7	5.5	7	2.7	5.5
8	-5.0	-5.0	8	-5.0	-5.0	8	-5.0	-5.0	8	-5.0	-5.0
9	0.0	0.0	9	0.0	0.0	9	0.0	0.0	9	0.0	0.0
10	0.0	0.0	10	0.0	0.0	10	0.0	0.0	10	0.0	0.0
11	0.0	0.0	11	0.0	0.0	11	0.0	0.0	11	0.0	0.0
12	0.0	0.0	12	0.0	0.0	12	0.0	0.0	12	0.0	0.0
13	0.0	0.0	13	0.0	0.0	13	0.0	0.0	13	0.0	0.0
14	-3.4	-3.4	14	-3.4	-3.4	14	-3.4	-3.4	14	-3.4	-3.4
15	1.5	1.5	15	1.5	1.5	15	1.5	1.5	15	1.5	1.5
16	5.9	5.9	16	5.9	5.9	16	5.9	5.9	16	5.9	5.9

NOTE:  
 1. ALL RESISTANCES VALUES ARE IN [ohm].  
 K=1000 [ohm] M=1000K [ohm]  
 2. THE MATTAGE OF RESISTANCES IS 1/4W UNLESS OTHERWISE NOTED.  
 3. ALL CAPACITANCES VALUES ARE IN uF UNLESS OTHERWISE NOTED.  
 P=UF  
 4. SAFETY REQUIREMENTS COMPONENTS IN ACCORDANCE WITH PRESENT SAFETY REGULATIONS.  
 5. THESE COMPONENTS MUST ONLY BE REPLACED BY ORIGINAL PARTS.

A B C D E F G

SCHEMATIC DIAGRAM (3)

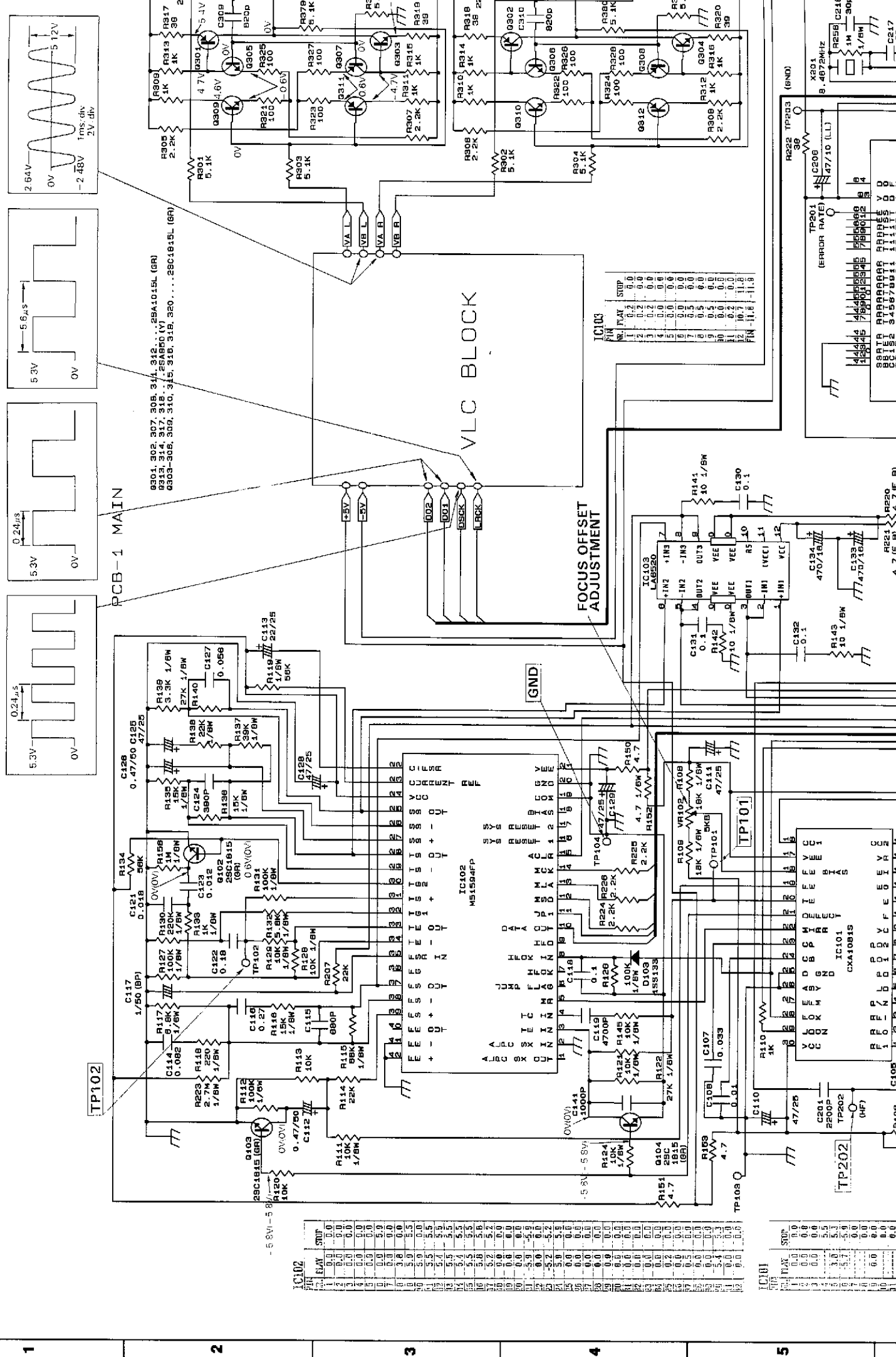

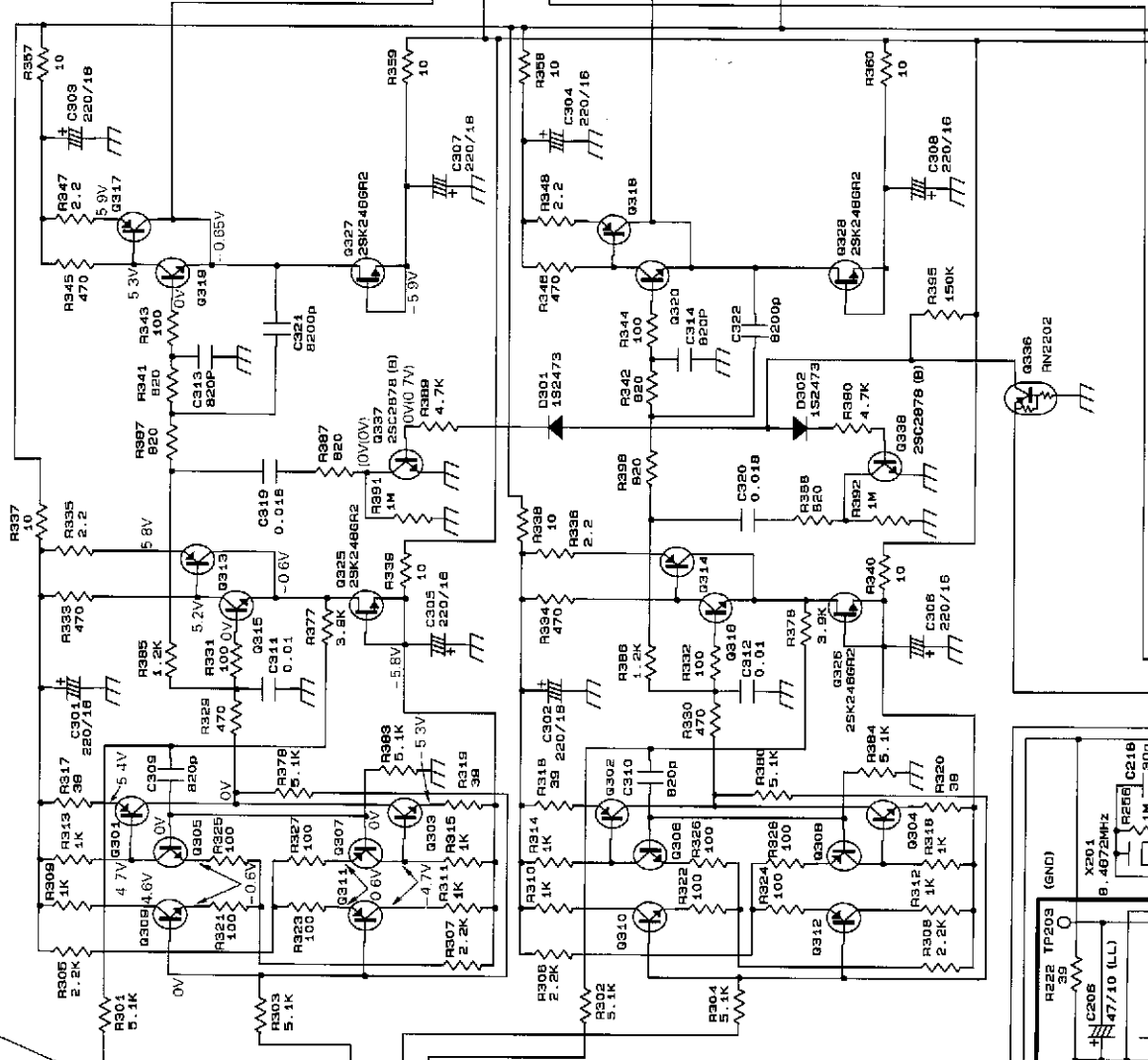
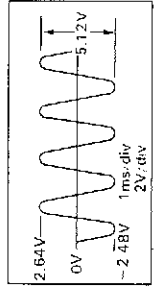

IC201

NO.	PLAY	STOP
1	0.0	0.0
2	2.0	0.0
3	2.0	0.0
4	2.0	0.0
5	0.0	0.0
6	0.0	0.0
7	5.0	0.0
8	0.0	0.0
9	0.0	0.0
10	0.0	0.0
11	2.0	0.0
12	2.0	0.0
13	2.0	0.0
14	2.0	0.0
15	2.0	0.0
16	0.0	0.0
17	2.0	0.0
18	2.0	0.0
19	2.0	0.0
20	2.0	0.0
21	2.0	0.0
22	2.0	0.0
23	2.0	0.0
24	0.0	0.0
25	2.0	0.0
26	2.0	0.0
27	2.0	0.0
28	2.0	0.0
29	2.0	0.0
30	0.0	0.0
31	2.0	0.0
32	2.0	0.0
33	2.0	0.0
34	2.0	0.0
35	2.0	0.0
36	2.0	0.0
37	2.0	0.0
38	2.0	0.0
39	2.0	0.0
40	0.0	0.0
41	0.0	0.0
42	0.0	0.0
43	0.0	0.0
44	0.0	0.0
45	0.0	0.0
46	0.0	0.0
47	0.0	0.0
48	0.0	0.0
49	0.0	0.0
50	0.0	0.0

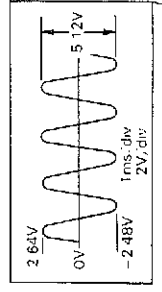

J801  
Leh.

J801  
FIXED  
OUTPUT

Ren.

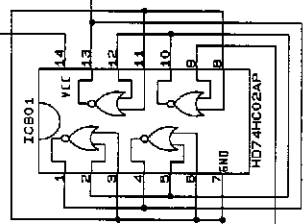

IC801

NO.	PLAY	STOP
1	2.0	2.0
2	2.0	2.0
3	0.0	0.0
4	2.0	2.0
5	2.0	2.0
6	0.0	0.0
7	0.0	0.0
8	0.0	0.0

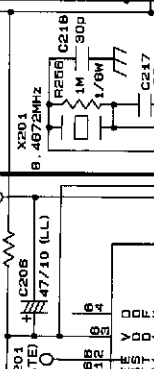
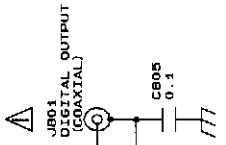

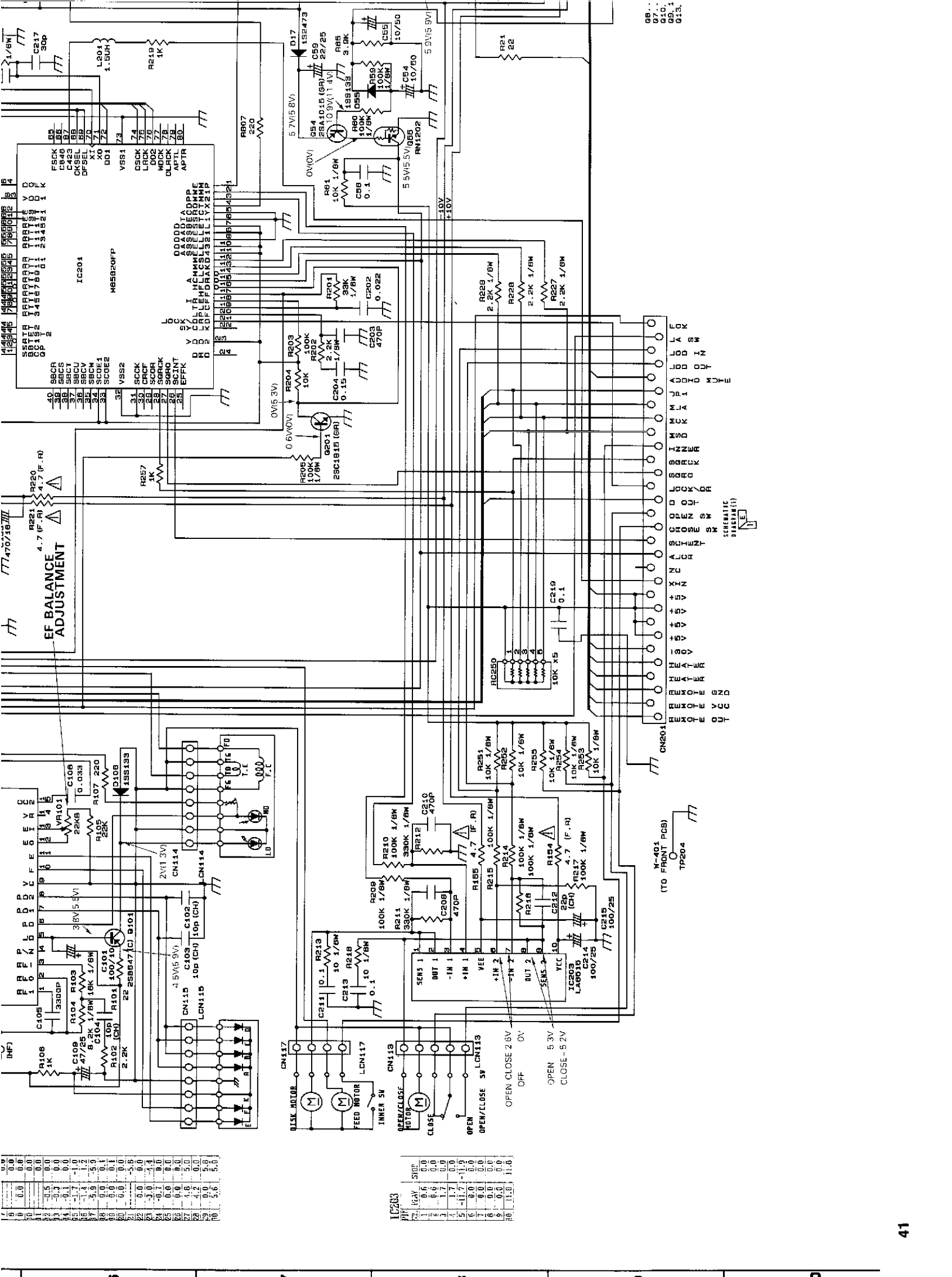

08...  
07...  
06...  
05...  
04...  
03...  
02...  
01...  
00...

EF BALANCE ADJUSTMENT

SCHEMATIC DIAGRAM (1)

W-FRONT PCB)  
TP204

Pin	Signal	Value
1	+	0.0
2	+	0.0
3	+	0.0
4	+	0.0
5	+	0.0
6	+	0.0
7	+	0.0
8	+	0.0
9	+	0.0
10	+	0.0
11	+	0.0
12	+	0.0
13	+	0.0
14	+	0.0
15	+	0.0
16	+	0.0
17	+	0.0
18	+	0.0
19	+	0.0
20	+	0.0
21	+	0.0
22	+	0.0
23	+	0.0
24	+	0.0
25	+	0.0
26	+	0.0
27	+	0.0
28	+	0.0
29	+	0.0
30	+	0.0
31	+	0.0
32	+	0.0
33	+	0.0
34	+	0.0
35	+	0.0
36	+	0.0
37	+	0.0
38	+	0.0
39	+	0.0
40	+	0.0
41	+	0.0
42	+	0.0
43	+	0.0
44	+	0.0
45	+	0.0
46	+	0.0
47	+	0.0
48	+	0.0
49	+	0.0
50	+	0.0
51	+	0.0
52	+	0.0
53	+	0.0
54	+	0.0
55	+	0.0
56	+	0.0
57	+	0.0
58	+	0.0
59	+	0.0
60	+	0.0
61	+	0.0
62	+	0.0
63	+	0.0
64	+	0.0
65	+	0.0
66	+	0.0
67	+	0.0
68	+	0.0
69	+	0.0
70	+	0.0
71	+	0.0
72	+	0.0
73	+	0.0
74	+	0.0
75	+	0.0
76	+	0.0
77	+	0.0
78	+	0.0
79	+	0.0
80	+	0.0
81	+	0.0
82	+	0.0
83	+	0.0
84	+	0.0
85	+	0.0
86	+	0.0
87	+	0.0
88	+	0.0
89	+	0.0
90	+	0.0
91	+	0.0
92	+	0.0
93	+	0.0
94	+	0.0
95	+	0.0
96	+	0.0
97	+	0.0
98	+	0.0
99	+	0.0
100	+	0.0

Pin	Signal	Value
1	+	0.0
2	+	0.0
3	+	0.0
4	+	0.0
5	+	0.0
6	+	0.0
7	+	0.0
8	+	0.0
9	+	0.0
10	+	0.0
11	+	0.0
12	+	0.0
13	+	0.0
14	+	0.0
15	+	0.0
16	+	0.0
17	+	0.0
18	+	0.0
19	+	0.0
20	+	0.0
21	+	0.0
22	+	0.0
23	+	0.0
24	+	0.0
25	+	0.0
26	+	0.0
27	+	0.0
28	+	0.0
29	+	0.0
30	+	0.0
31	+	0.0
32	+	0.0
33	+	0.0
34	+	0.0
35	+	0.0
36	+	0.0
37	+	0.0
38	+	0.0
39	+	0.0
40	+	0.0
41	+	0.0
42	+	0.0
43	+	0.0
44	+	0.0
45	+	0.0
46	+	0.0
47	+	0.0
48	+	0.0
49	+	0.0
50	+	0.0
51	+	0.0
52	+	0.0
53	+	0.0
54	+	0.0
55	+	0.0
56	+	0.0
57	+	0.0
58	+	0.0
59	+	0.0
60	+	0.0
61	+	0.0
62	+	0.0
63	+	0.0
64	+	0.0
65	+	0.0
66	+	0.0
67	+	0.0
68	+	0.0
69	+	0.0
70	+	0.0
71	+	0.0
72	+	0.0
73	+	0.0
74	+	0.0
75	+	0.0
76	+	0.0
77	+	0.0
78	+	0.0
79	+	0.0
80	+	0.0
81	+	0.0
82	+	0.0
83	+	0.0
84	+	0.0
85	+	0.0
86	+	0.0
87	+	0.0
88	+	0.0
89	+	0.0
90	+	0.0
91	+	0.0
92	+	0.0
93	+	0.0
94	+	0.0
95	+	0.0
96	+	0.0
97	+	0.0
98	+	0.0
99	+	0.0
100	+	0.0



3	0.0	0.0
4	2.6	2.6
5	2.6	2.6
6	0.0	0.0
7	0.0	0.0
8	0.0	0.0
9	2.6	2.6
10	2.6	2.6
11	0.0	0.0
12	2.6	2.6
13	2.6	2.6
14	5.3	5.4

PCB-4 POWER SUPPLY

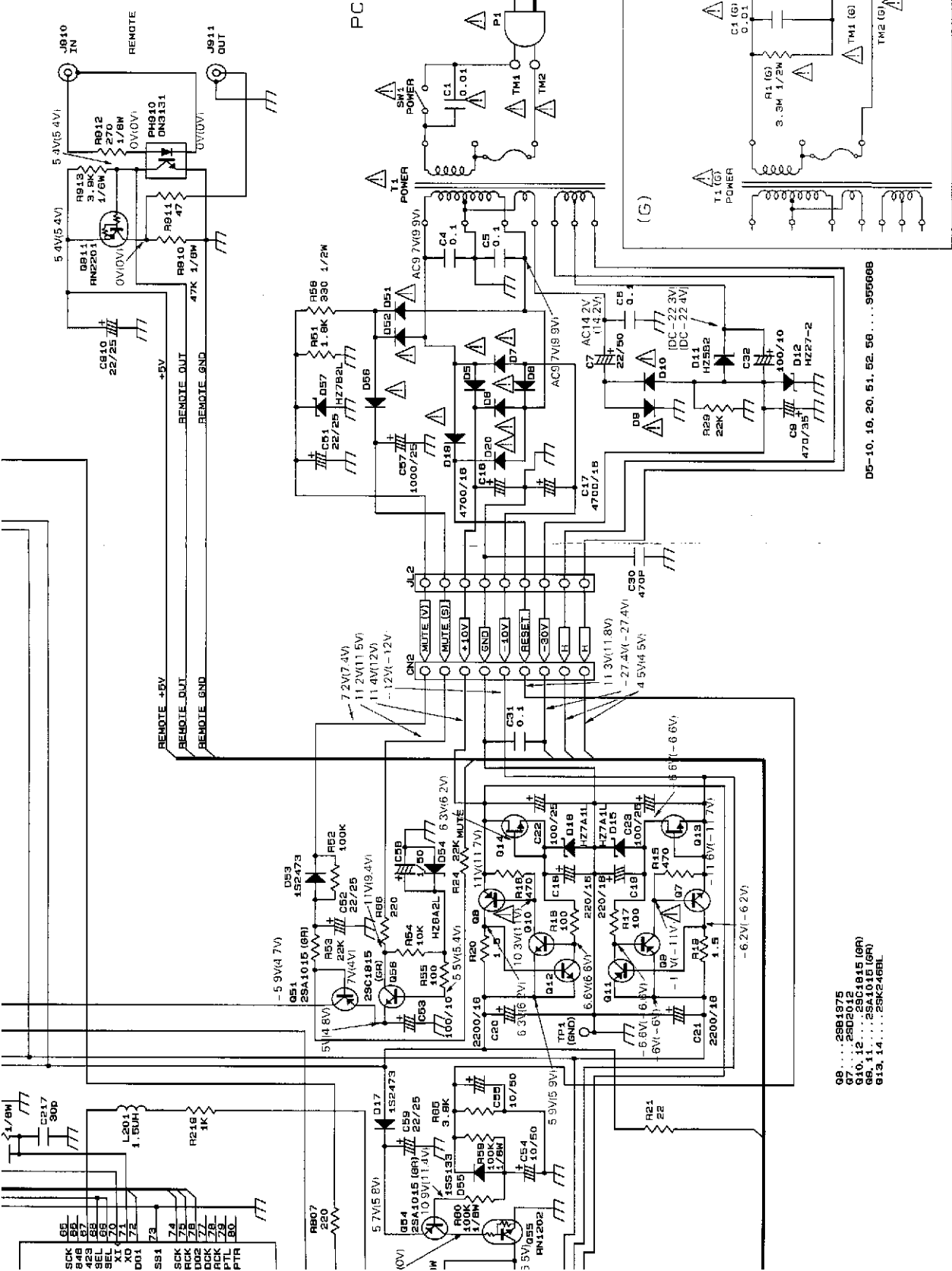

- NOTE :
1. ALL RESISTANCE VALUES ARE IN [ohm].
  2. K=1000 [ohm], M=1000K [ohm].
  3. THE MAXIMUM RESISTANCE IS 1/4W UNLESS OTHERWISE NOTED.  
P=1/2W, P=1/2W, P=1/2W.
  4. SAFETY REQUIREMENTS COMPONENTS IN ACCORDANCE WITH PRESENT SAFETY REGULATIONS.
  5. THESE COMPONENTS MUST ONLY BE REPLACED BY ORIGINAL PARTS.

Q8 .....28B1875  
 Q9 .....28D2012  
 G10,12 .....28C1615 (GR)  
 G6,11 .....28A1010 (GR)  
 G13,14 .....28K2468L

D5-10, 10, 20, 51, 52, 56 ..... 9556608

# WIRING DIAGRAM

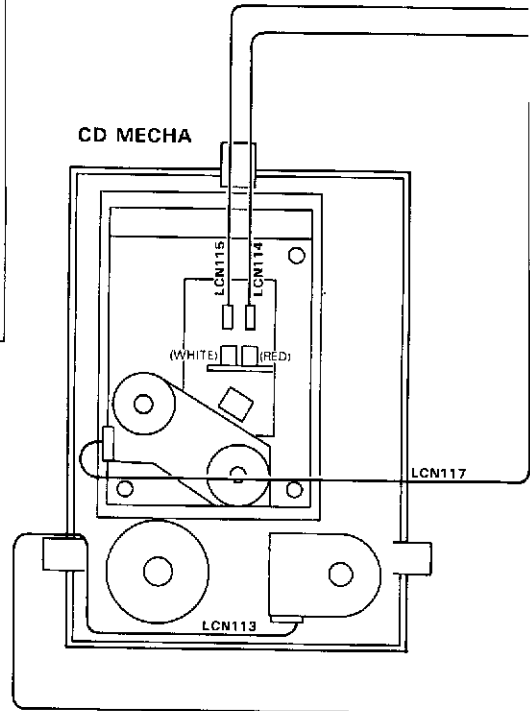
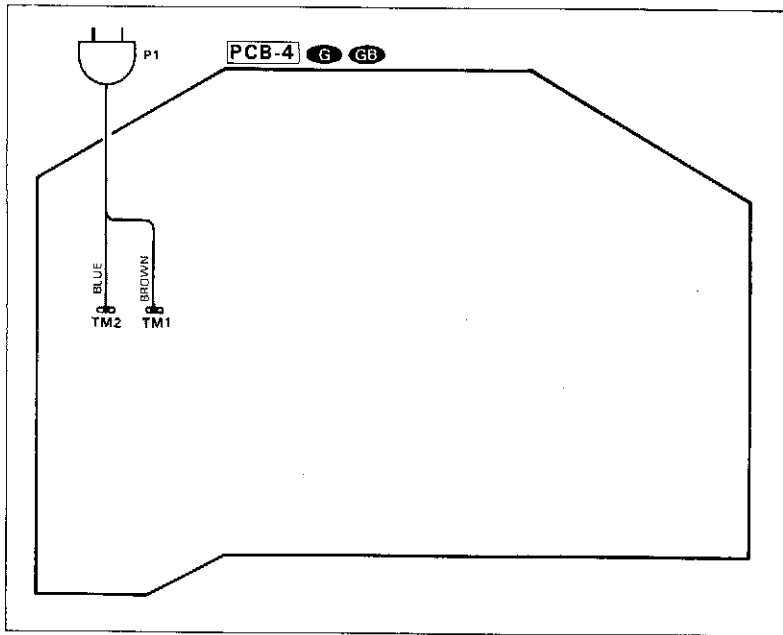
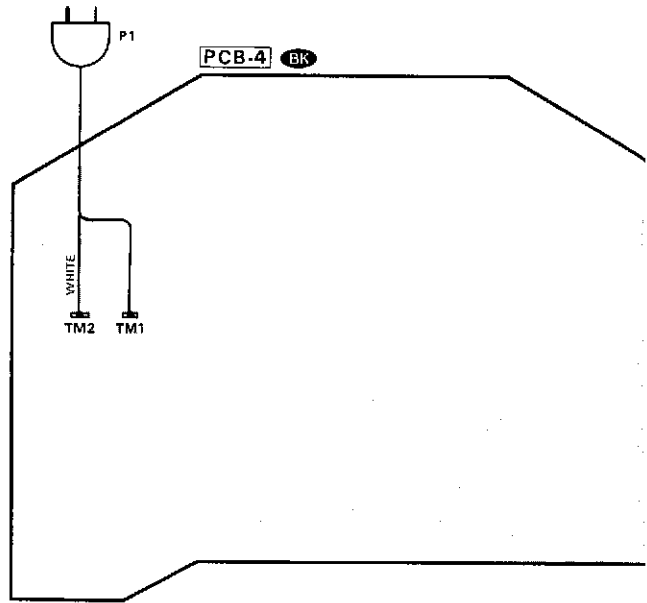

PCB-1

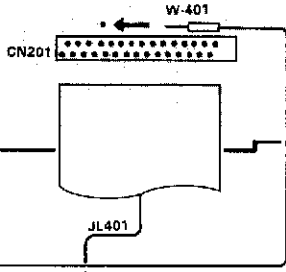
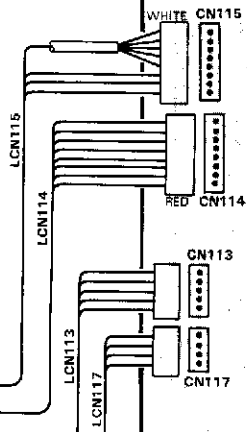
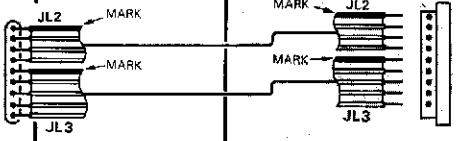

PCB-2



CN117